

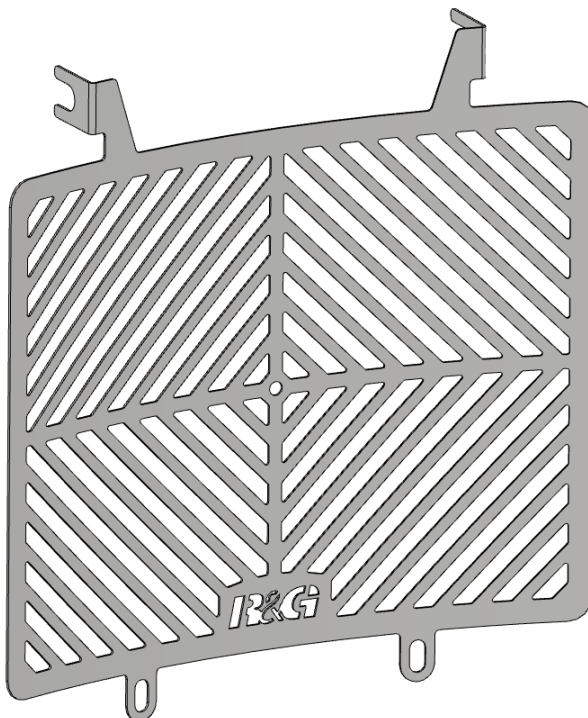

FITTING INSTRUCTIONS FOR SRG0078SS
STAINLESS-STEEL RADIATOR GUARD
HUSQVARNA SVARTPILEN 701 2019-



THIS KIT CONTAINS THE ITEMS PICTURED AND LABELLED OVER PAGE.

SOME PARTS MAY BE SHOWN FOR CLARITY OF INSTRUCTIONS ONLY.

DO NOT PROCEED UNTIL YOU ARE SURE ALL PARTS ARE PRESENT.

PLEASE READ ALL INSTRUCTIONS BEFORE PROCEEDING.

**IF IN ANY DOUBT WHEN FITTING OUR PRODUCTS, CONSULT ONE OF OUR DEALERS
OR HAVE FITTED BY A QUALIFIED TECHNICIAN.**

PLEASE NOTE THAT THE WAY THE KIT IS PACKED DOES NOT NECESSARILY REPRESENT THE WAY OF
MOUNTING TO THE BIKE.

IN THE EVENT OF RUBBER WASHERS BEING USED TO HOLD COMPONENTS ONTO BOLTS,
THESE RUBBER WASHERS CAN BE THROWN AWAY.

DIGITAL COPIES OF THESE INSTRUCTIONS ARE AVAILABLE FROM:

WWW.RG-RACING.COM

R&G Racing
Unit 1, Shelley's Lane, East Worldham, Alton, Hampshire, GU34 3AQ
Tel: +44 (0)1420 89007 Fax: +44 (0)1420 87301 www.rg-racing.com Email: info@rg-racing.com



<u>TOOLS REQUIRED</u>	<u>GENERAL TORQUE SETTINGS</u>
<ul style="list-style-type: none"> · Set of metric Allen keys to include 4mm · 8mm socket or spanner 	<p>M4 BOLT = 8Nm</p> <p>M5 BOLT = 12Nm</p> <p>M6 BOLT = 15Nm</p> <p>M8 BOLT = 20Nm</p> <p>M10 BOLT = 40Nm</p> <p>M12 BOLT = 40Nm</p>

LEGEND

ITEM NO.	DESCRIPTION	QTY
ITEM 1	SS RAD0078 RADIATOR GUARD	1
ITEM 2	6MM x 15MM LONG BUTTON HEAD BOLT	2
ITEM 3	6MM WASHER	2
ITEM 4	100mm LENGTH OF SELF-ADHESIVE FOAM	4

FITTING PICTURES

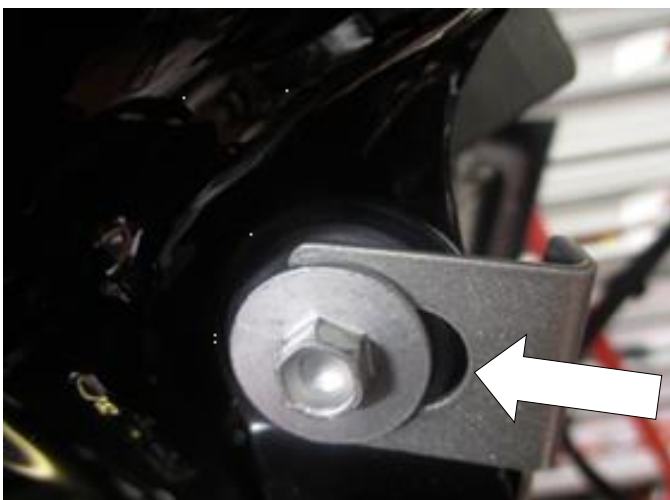

Picture 1



Picture 2



FITTING INSTRUCTIONS

- To fit the radiator guard, first cut the foam strips (item 4) provided into 10mm wide pieces and stick them to the rear of the radiator guard frame (item 1), so that they will sit between the radiator guard and the radiator when fitted.
- Loosen the two mount bolts on top of the radiator, found on each side of the bike. Do not remove bolts fully as the radiator guard tabs will sit over the exposed bolt threads as shown in **picture 1**.
- Offer the radiator guard into position ensuring to locate the tabs over the exposed thread of the bolts.
- Before tightening make sure the radiator guard is located so the tab is covered by the bolt head. Now tighten both bolts to the recommended torque.
- Next, place one washer (item 3) over each M6 bolt (item 2) and insert one bolt each side through the lower radiator guard mount tab and into the lower radiator mount as shown in **picture 2** and tighten to the recommended torque.
- Ensure the radiator guard is correctly mounted and secure before riding the motorcycle.

ISSUE 1 - 28/08/2020 (DM)

CONSUMER NOTICE

The catalogue description and any exhibition of samples are only broad indications of the Products and R&G may make design changes which do not diminish their performance or visual appeal and supplying them in such state shall conform to the order. The Buyer acknowledges no representation or warranty (other than as to title) has been given or will apply to the Products other than those in R&G's order or confirmation and the Buyer confirms it has chosen the Products as being of merchantable quality and suitable for its particular purposes. Where R&G fits the Products or undertakes other services it shall exercise reasonable skill and care and rectify any fault free of charge unless the workmanship has been disturbed. The Buyer is responsible for ensuring that the warranty on the motorcycle is not affected by the fitting of the Products. On return of any defective Products R&G shall at its option either supply a replacement or refund the purchase money but shall not be liable if the Products have been modified or used or maintained otherwise than in accordance with R&G's or manufacturer's instructions and good engineering practice or if the defect arises from accident or neglect. Other than identified above and subject to R&G not limiting its liability for causing death and personal injury, it shall not be liable for indirect or consequential loss and otherwise its liability shall be limited to the amounts paid by the Buyer for the Products or the fitting or service concerned. These terms do not affect the Buyer's statutory rights.

R&G RACING RETURNS POLICY (NON-FAULTY GOODS)

Returns must be pre-authorized (if not pre-authorized the return will be rejected). Goods may only be returned direct to us if they were purchased direct from us (customer must prove if necessary). Otherwise to be returned to original vendor. Goods must be in re-sellable condition, in the opinion of R&G Racing. All returns are subject to a 25% restocking and handling fee (25% of the gross value exc. P&P – at the prevailing price at time of purchase). The customer must pay any and all carriage charges. No returns of discontinued products, unless within 14 days of purchase. This policy does not affect your statutory rights and does not refer to faulty goods.

R&G Racing

Unit 1, Shelley's Lane, East Worldham, Alton, Hampshire, GU34 3AQ

Tel: +44 (0)1420 89007 Fax: +44 (0)1420 87301 www.rg-racing.com Email: info@rg-racing.com



NOTICE DE MONTAGE POUR SRG0078SS
PROTECTION RADIATEUR
HUSQVARNA SVARTPILEN 701 2019-

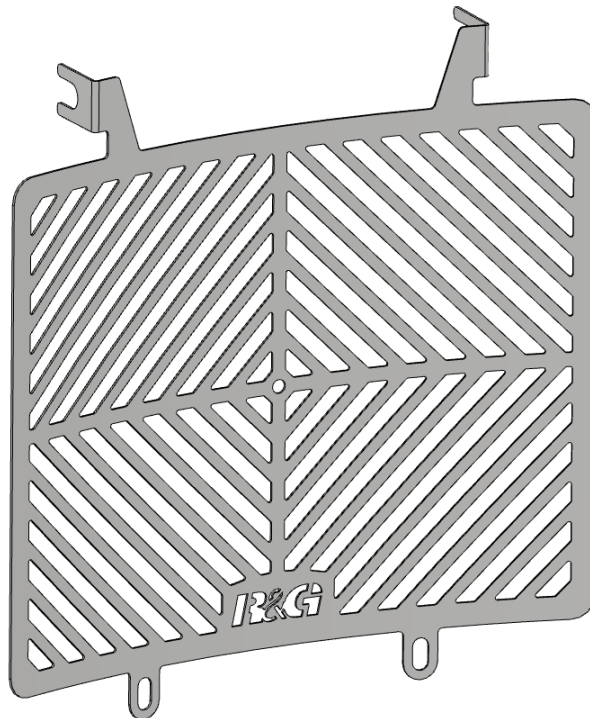

CE KIT CONTIENT LES ARTICLES ILLUSTRÉS ET ÉTIQUETES SUR LA PAGE.

CERTAINES PARTIES PEUVENT ÊTRE PRÉSENTES UNIQUEMENT POUR LA CLARTÉ DES INSTRUCTIONS.

NE PAS PROCÉDER AU MONTAGE TANT QUE VOUS N'ÊTES PAS SÛR QUE TOUTES LES PIÈCES SOIENT PRÉSENTES.

VEUILLEZ LIRE TOUTES LES INSTRUCTIONS AVANT DE CONTINUER.

EN CAS DE DOUTE LORS DU MONTAGE DE NOS PRODUITS, CONSULTEZ UN DE NOS REVENDEURS OU FAITES APPEL À UN TECHNICIEN QUALIFIÉ.

VEUILLEZ NOTER QUE LA FAÇON DONT LE KIT EST EMBALLÉ NE REPRÉSENTE PAS NECESSAIREMENT LA MANIÈRE DE LE MONTER SUR LA MOTO.

SI DES RONDELLES EN CAOUTCHOUC SONT UTILISÉES POUR MAINTENIR LES COMPOSANTS SUR LES BOULONS, ELLES PEUVENT ÊTRE JETÉES.

NOTICE DISPONIBLE AU TÉLÉCHARGEMENT SUR :

WWW.RG-RACING.COM



<u>OUTILS REQUIS</u>	<u>VALEURS DE SERRAGE</u>
· Clé Allen 4mm	M4 BOULON = 8Nm
· Clé à cliquet + douille 8mm	M5 BOULON = 12Nm
	M6 BOULON = 15Nm
	M8 BOULON = 20Nm
	M10 BOULON = 40Nm
	M12 BOULON = 40Nm

LÉGENDE

ARTICLE NO.	DESCRIPTION	QTÉ
ARTICLE 1	SS RAD0078 PROTECTION RADIATEUR	1
ARTICLE 2	6MM x 15MM BOULON	2
ARTICLE 3	6MM RONDELLE	2
ARTICLE 4	100mm MOUSSE AUTOCOLLANTE	4

NOTICE DE MONTAGE

- Pour monter la protection de radiateur, coupez d'abord les bandes de mousse (article 4) fournies en morceaux de 10 mm de large et collez-les au bas du cadre de protection de radiateur (article 1), de manière à ce qu'elles reposent entre la protection de radiateur et le radiateur.
- Desserrez les deux boulons de fixation sur le dessus du radiateur, situés de chaque côté de la moto. Ne retirez pas complètement les boulons car les languettes de protection du radiateur reposeront sur les filetages des boulons exposés comme indiqué sur la photo 1.
- Présentez la protection radiateur en position en veillant à placer les languettes sur le filetage exposé des boulons.
- Avant de serrer, assurez-vous que la protection du radiateur soit située de sorte que la languette soit couverte par la tête du boulon. Serrez maintenant les deux boulons au couple recommandé.
- Ensuite, placez une rondelle (article 3) sur chaque boulon M6 (article 2) et insérez un boulon de chaque côté à travers la languette de montage de la protection radiateur inférieure et dans le support de radiateur inférieur comme indiqué sur la photo 2 et serrez au couple recommandé.
- Assurez-vous que la protection radiateur soit correctement montée et sécurisée avant de conduire la moto.

ISSUE 1 - 28/08/2020 (DM)



MONTAGEANLEITUNG FÜR SRG0078SS
EDELSTAHL KÜHLERSCHUTZ
HUSQVARNA SVARTPILEN 701 2019-

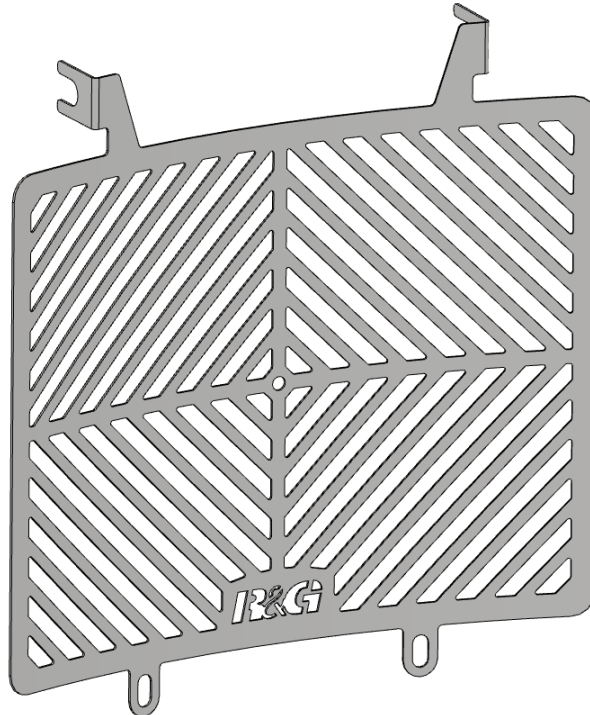

ALLE KIT-TEILE SIND UNTEN ABGEBILDET UND GEKENNZEICHNET.

DIE ABGEBILDETEN TEILE DIENEN LEDIGLICH ZUR ERKLÄRUNG.

ÜBERPRÜFEN SIE ZUERST, DASS ALLE TEILE VORHANDEN SIND.

LESEN SIE DIE MONTAGEANLEITUNG KOMPLETT DURCH, BEVOR SIE ANFANGEN.

WENN SIE BEI DER MONTAGE DIESES PRODUKTES UNSICHER SIND, BITTE EINEN UNSERER HÄNDLER KONTAKTIEREN ODER DAS KIT VON EINEM QUALIFIZIERTEN ZWEIRADMECHANIKER MONTIEREN LASSEN.

DIE VERPACKUNG DER TEILE STELLT NICHT DIE REIHENFOLGE DER MONTAGE DAR.

HINWEIS FÜR KITS MIT PLASTIKUNTERLEGSCHLEIBEN AN DEN SCHRAUBEN –
DIESE PLASTIK-UNTERLEGSCHLEIBEN WERDEN NICHT FÜR DEN EINBAU BENÖTIGT!

**EINE DIGITALE VERSION DIESER MONTAGEANLEITUNG KANN AUF
FOLGENDER SEITE HERUNTERGELADEN WERDEN: WWW.RG-RACING.COM**



<u>SIE BENÖTIGEN FOLGENDES WERKEZEUG:</u>	<u>ALLGEM. ANZUGSDREHMOMENT:</u>
<ul style="list-style-type: none"> • Satz Inbusschlüssel inkl. 4mm Inbusschlüssel • 8mm Steckschlüssel oder Schraubenschlüssel 	M4 SCHRAUBE = 8Nm M5 SCHRAUBE = 12Nm M6 SCHRAUBE = 15Nm M8 SCHRAUBE = 20Nm M10 SCHRAUBE = 40Nm M12 SCHRAUBE = 40Nm

LIEFERUMFANG

ARTIKEL NR.	BESCHREIBUNG	MENGE
ARTIKEL 1	SS RAD0078 KÜHLERSCHUTZ	1
ARTIKEL 2	6MM x 15MM INBUSSCHRAUBE	2
ARTIKEL 3	6MM UNTERLEGSCHIEBE	2
ARTIKEL 4	100mm SELBSTKLEBENER SCHAUMSTOFFSTREIFEN	4

MONTAGEANLEITUNG

- Um den Kühlerschutz am Motorrad montieren zu können, schneiden Sie zuerst die mitgelieferten Schaumstoffstreifen (Artikel 4) in 10 mm breite Stücke und kleben Sie diese auf der Rückseite des Kühlerschutzrahmens (Artikel 1), so dass sie zwischen dem Kühlerschutz und dem Kühler angebracht sind.
- Lösen Sie die zwei Montageschrauben oben am Kühler an beiden Seiten des Motorrades. Die zwei Schrauben dabei nicht komplett entfernen, weil die Laschen für den Kühler an den hervorstehenden Enden der Schraubengewinde sitzen wie in **Abbildung 1** abgebildet.
- Den Kühlerschutz in Position bringen und darauf achten, dass die Laschen über den hervorstehenden Gewinden der Schrauben montiert sind.
- Bevor Sie alles befestigen, stellen Sie sicher, dass der Kühlerschutz entsprechend montiert ist, so dass die Lasche vom Schraubenkopf bedeckt ist. Danach beide Schrauben mit dem empfohlenen Anzugsdrehmoment festziehen.
- Als nächstes, jeweils eine Unterlegscheibe (Artikel 3) an beiden M6 Schrauben (Artikel 2) anbringen. Die zwei Schrauben an den unteren Montagelaschen des Kühlers an beiden Seiten des Kühlerschutzes einführen und in die untere Kühlerhalterung einsetzen wie in **Abbildung 2** abgebildet und anschließend mit dem empfohlenen Anzugsdrehmoment befestigen.
- Überprüfen Sie, dass der Kühlerschutz sicher montiert und befestigt ist, bevor Sie mit dem Motorrad fahren.

AUSGABE 1 - 28/08/2020 (DM)

R&G Racing

Unit 1, Shelley's Lane, East Worldham, Alton, Hampshire, GU34 3AQ

Tel: +44 (0)1420 89007 Fax: +44 (0)1420 87301 www.rg-racing.com Email: info@rg-racing.com