



**FITTING INSTRUCTIONS FOR LP0233BK LICENCE PLATE BRACKET**  
**YAMAHA T-MAX '17-**



**THIS KIT CONTAINS THE ITEMS PICTURED AND LABELLED BELOW.**  
**DO NOT PROCEED UNTIL YOU ARE SURE ALL PARTS ARE PRESENT.**

Please note that the way the kit is packed does not necessarily represent the way of mounting to the bike.

THE PARTS SHOWN MAY BE REPRESENTATIVE ONLY (FOR CLARITY OF INSTRUCTIONS ONLY).

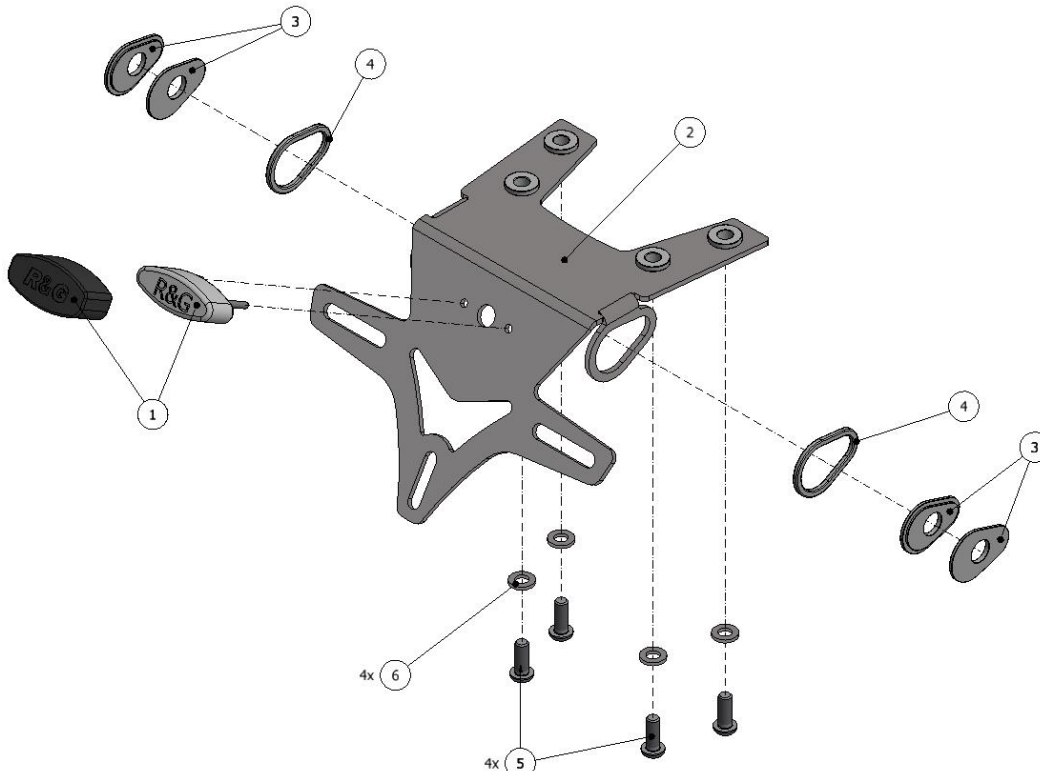

R&G Racing

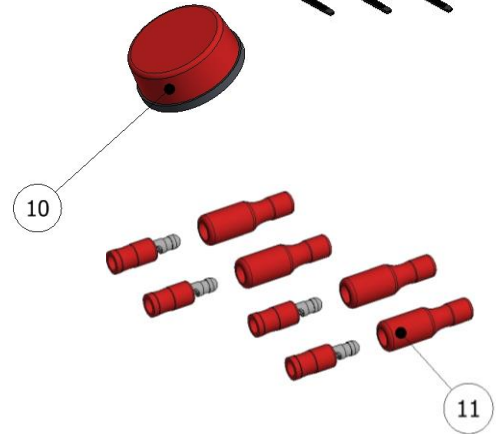
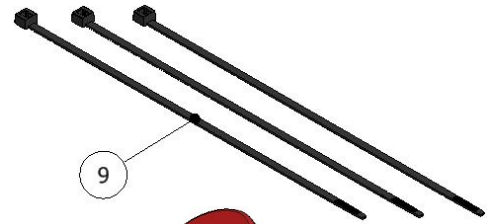
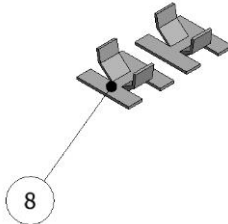
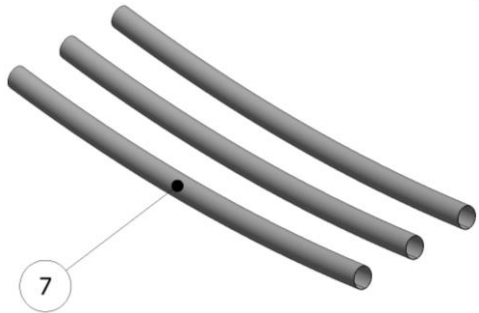

**LEGEND**

- ITEM 1 = LICENCE PLATE ILLUMINATOR & SHROUD (LA0002) (x1).
- ITEM 2 = LICENCE PLATE BRACKET (TB0233) (x1).
- ITEM 3 = MINI INDICATOR ADAPTORS (I0016) (x4).
- ITEM 4 = OEM INDICATOR ADAPTORS (I0037) (x2).
- ITEM 5 = M6 x 16mm LONG BUTTON HEAD BOLTS (x4).
- ITEM 6 = M6 WASHERS (x4).
- ITEM 7 = 150mm LENGTH OF HEATSHRINK (x3).
- ITEM 8 = SELF-ADHESIVE CABLE CLIPS (x2).
- ITEM 9 = 2.5mm CABLE TIES (x3).
- ITEM 10 = REFLECTOR (x1).
- ITEM 11 = BULLET CONNECTORS (CON0004) (x2).

Please note that in cases where kits are packed with rubber washers holding the components onto the bolt – *the rubber washers should be thrown away!*

**TOOLS REQUIRED**

- Set of metric Allen keys.
- Set of metric sockets and wrench.
  - 12mm spanner.
  - Phillips screwdriver.
  - Cable cutters.

**MAXIMUM TORQUE SETTINGS**

- M4 Bolt = 8 Nm
- M5 Bolt = 12 Nm
- M6 Bolt = 15 Nm
- M8 Bolt = 20 Nm



Picture 1



Picture 2



Picture 3



Picture 4

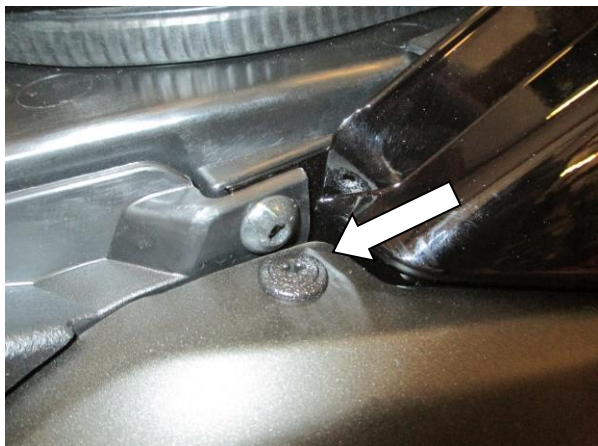

Picture 5

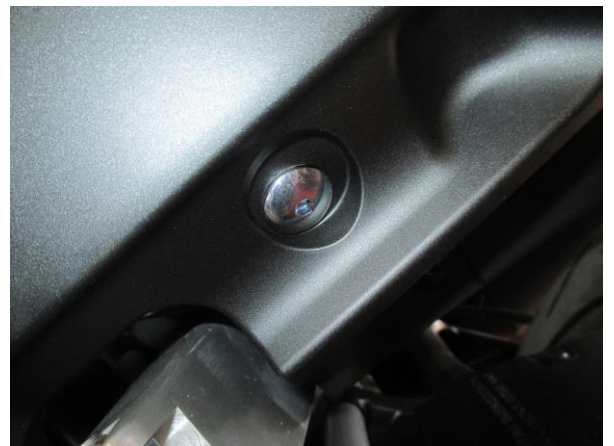

Picture 6



Picture 7



Picture 8



Picture 9



Picture 10



Picture 11

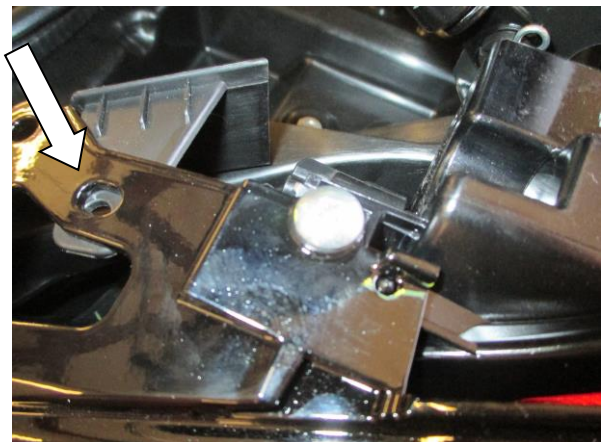

Picture 12



Picture 13



Picture 14



Picture 15



Picture 16



Picture 17



Picture 18

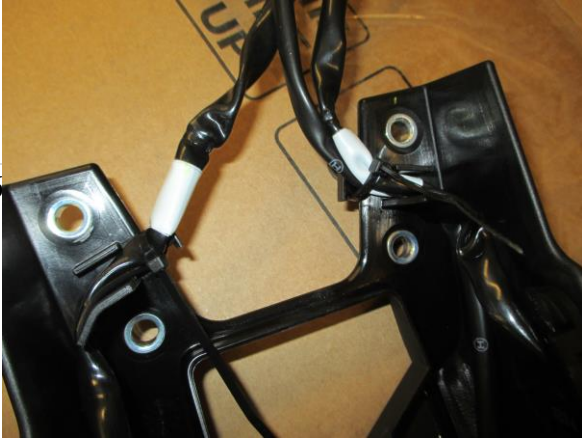

Picture 19



Picture 20



Picture 21



Picture 22



Picture 23



Picture 24

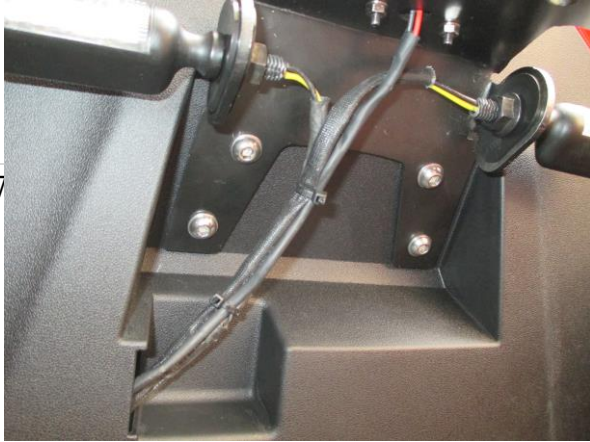

Picture 25



Picture 26

### **FITTING INSTRUCTIONS**

- To fit the R&G tail tidy, lift the seat.
- Remove the two plastic covers on the hand rail on the left side of the bike, as arrowed in picture 1, and remove the two bolts underneath. Remove the hand rail from the bike.
- On the rear plastic surround, lift the corner of the rubber cover to gain access to the bolt underneath, as shown in picture 2. Remove this bolt, along with the one on the right side, before removing the panel that is shown in picture 3.
- The large body coloured side panel that is shown in picture 4 now needs to be removed. To do this, remove the plastic fastener shown in picture 5, along with the bolt that is hidden behind the folded pillion foot peg, as shown in picture 6, and the two bolts that are shown in picture 7. With all fixings removed, gently pull the panel away from the bike, releasing the rubber push mount toward the rear and remove from the bike.
- Remove the bolt that is now exposed holding the rear bodywork in place towards the front of the seat, as shown in picture 8.
- Remove the four push rivets that secure the inner panel to the bodywork, as shown in pictures 9, 10 & 11.
- Remove the bolt and the push rivet securing the rear of the bodywork in place, as shown in picture 12.
- Remove the bolt that is next to the rubber mounting hole, as shown in picture 13.
- The side panel that is shown in picture 14 can now be removed from the bike by gently pulling clear.
- Access can now be gained to the licence plate and indicator wiring connectors. Disconnect the large black and large white connector, along with the two bullet connectors, as shown in picture 15.
- On the underside of the OEM licence plate hanger, remove the four bolts, as shown in picture 16. Support this bracket whilst feeding the wiring out and remove from the bike, as shown in picture 17.
- Take the R&G Licence Plate bracket (item 2 – TB0233) and fit the R&G licence plate illuminator (item 1 – LA0002) to the bracket, as shown in picture 18. Fit one length of heatshrink to the wires, tighten the nuts on the rear and use a small amount of super glue to secure the light shroud in place.

### ***If fitting Mini Indicators***

- To fit the R&G Mini Indicators, fit one length of heatshrink to the wires of each indicator.
- Feed the wiring of either indicator through the hole in one of the mini indicator adaptors (item 3 – I0016), ensuring the raised boss on the adaptors face away from the indicator.
- Feed the indicator wiring through the hole on the licence plate bracket, positioning the raised boss on the adaptor within the hole, before positioning a second mini indicator adaptor (item 3 – I0016) (with the boss facing toward

R&G Racing

Unit 1, Shelley's Lane, East Worldham, Alton, Hampshire, GU34 3AQ

Tel: +44 (0)1420 89007 Fax: +44 (0)1420 87301 [www.rg-racing.com](http://www.rg-racing.com) Email: [info@rg-racing.com](mailto:info@rg-racing.com)



the indicator) over the wiring and into the hole on the bracket, before fitting the indicator nut over the wiring and tighten onto the threaded stalk of the indicator, as shown in picture 23.

- Fit the other indicator the same way in the remaining indicator mount, ensuring the R&G logo is facing upwards.

#### *If fitting OEM Indicators*

Page | 8

- Start off by removing the OEM indicators from the OEM licence plate hanger. Cut the two cable clips, as shown in picture 19, before removing the plastic piece from the rubber mount of the indicator. With this removed, pull the rubber mount of the plastic hole and feed the indicator and wiring clear of the OEM licence plate hanger, as shown in picture 20.
- Locate one of the OEM indicator adaptors (item 4 – I0037) over the runner mount of the OEM indicator, as shown in picture 21.
- Fit each indicator to the R&G indicator bracket by feeding the indicator wiring through the large hole on the licence plate bracket and locate the rubber with the hole, before refitting the plastic plate to secure in place, as shown in picture 22.
- With the indicators securely fitted, neatly route the wiring with the licence plate illuminator wiring using the cable ties and cable clips supplied, as shown in picture 23.
- Take the tail tidy assembly and offer it up underneath the tail whilst feeding the three sets of wires up through the small hole where the OEM wiring exited from, as shown in picture 24.
- Take the four M6 x 16mm long button head bolts (item 5) and four M6 washers (item 6) and fit through the four mounting holes of the tail tidy before tightening into the threaded bosses on the subframe, as shown in picture 25.
- Connect the licence plate illuminator wiring to the OEM connectors using the bullet connectors already fitted.
- If using the original indicators, reconnect the connectors to those on the main loom.
- If fitting Mini Indicators, the wiring on the OEM indicators will need to be “cut & shut” to re-use the wiring connectors. To do this, cut the connector off each indicator with approximately 100mm of wiring still attached. Strip the end of the wiring and fit the female bullet connectors supplied (item 11) to the exposed end of the wiring and this can now be connected to the bullet connectors on the mini indicators.
- If illumination fails on any light, re-connect the bullet connectors the other way around.
- Check for the correct operation of all lights.
- Ensure the wiring is all neatly routed behind the panel, as shown in picture 26.
- Re-fit the three pieces of bodywork and the hand rails in a reverse procedure of how they were removed.
- Re-fit the licence plate (it may require drilling).
- Depending on local laws, attach enclosed reflector in an appropriate location.
- Test the licence plate illuminator and all lights before riding.

ISSUE 1 31/08/2017 (AR)

**Digital copies of these instructions are available to download from [www.rg-racing.com](http://www.rg-racing.com)**

#### **CONSUMER NOTICE**

The catalogue description and any exhibition of samples are only broad indications of the Products and R&G may make design changes which do not diminish their performance or visual appeal and supplying them in such state shall conform to the order. The Buyer acknowledges no representation or warranty (other than as to title) has been given or will apply to the Products other than those in R&G's order or confirmation and the Buyer confirms it has chosen the Products as being of merchantable quality and suitable for its particular purposes. Where R&G fits the Products or undertakes other services it shall exercise reasonable skill and care and rectify any fault free of charge unless the workmanship has been disturbed. The Buyer is responsible for ensuring that the warranty on the motorcycle is not affected by the fitting of the Products. On return of any defective Products R&G shall at its option either supply a replacement or refund the purchase money but shall not be liable if the Products have been modified or used or maintained otherwise than in accordance with R&G's or manufacturer's instructions and good engineering practice or if the defect arises from accident or neglect. Other than identified above and subject to R&G not limiting its liability for causing death and personal injury, it shall not be liable for





indirect or consequential loss and otherwise its liability shall be limited to the amounts paid by the Buyer for the Products or the fitting or service concerned. These terms do not affect the Buyer's statutory rights.

**R&G RACING RETURNS POLICY (NON-FAULTY GOODS)**

Returns must be pre-authorized (if not pre-authorized the return will be rejected). Goods may only be returned direct to us if they were purchased direct from us (customer must prove if necessary). Otherwise to be returned to original vendor. Goods must be in re-sellable condition, in the opinion of R&G Racing. All returns are subject to a 25% restocking and handling fee (25% of the gross value exc. P&P – at the prevailing price at time of purchase). The customer must pay any and all carriage charges. No returns of discontinued products, unless within 14 days of purchase. This policy does not affect your statutory rights and does not refer to faulty goods.



**NOTICE DE MONTAGE POUR LP0233BK SUPPORT DE PLAQUE  
YAMAHA T-MAX '17-**



**Le kit contient les articles exposés ci-dessous, vérifier que toutes les pièces soient présentes avant de procéder au montage.**

**La façon dont le kit est emballé ne correspond pas forcément à la façon de monter les pièces sur la moto.**

**LES PARTIES PRESENTEES PEUVENT ETRE UNIQUEMENT REPRESENTATIVES (POUR LA CLARTE DES INSTRUCTIONS UNIQUEMENT).**

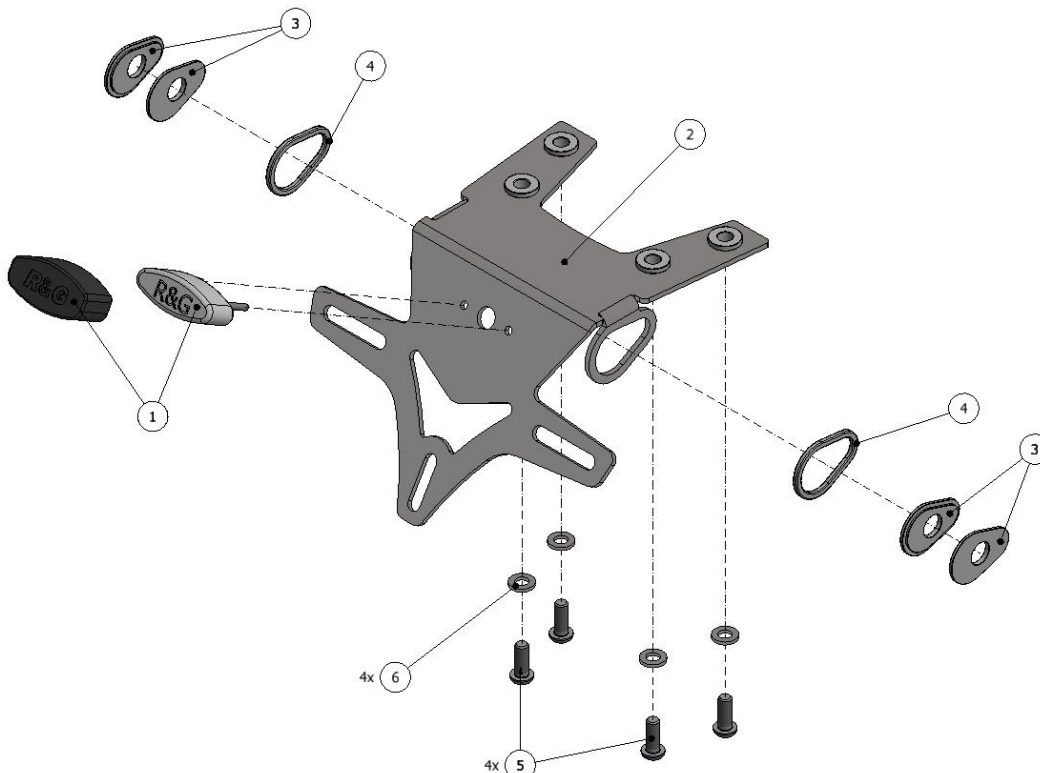

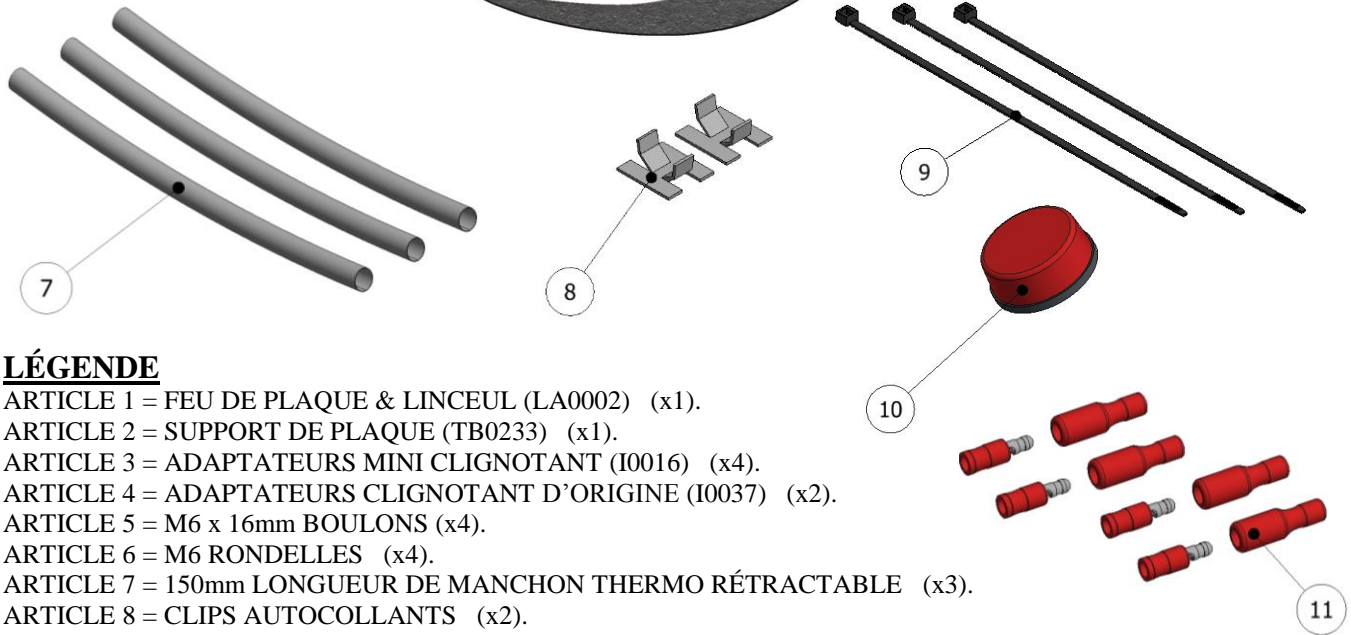

**LÉGENDE**

- ARTICLE 1 = FEU DE PLAQUE & LINCEUL (LA0002) (x1).
- ARTICLE 2 = SUPPORT DE PLAQUE (TB0233) (x1).
- ARTICLE 3 = ADAPTATEURS MINI CLIGNOTANT (I0016) (x4).
- ARTICLE 4 = ADAPTATEURS CLIGNOTANT D'ORIGINE (I0037) (x2).
- ARTICLE 5 = M6 x 16mm BOULONS (x4).
- ARTICLE 6 = M6 RONDELLES (x4).
- ARTICLE 7 = 150mm LONGUEUR DE MANCHON THERMO RÉTRACTABLE (x3).
- ARTICLE 8 = CLIPS AUTOCOLLANTS (x2).
- ARTICLE 9 = 2.5mm COLLIERS DE SERRAGE (x3).
- ARTICLE 10 = REFLECTEUR (x1).
- ARTICLE 11 = CONNECTEURS (CON0004) (x2).

Notez que si les kits sont emballés avec des rondelles en caoutchouc servant à tenir les composants, ces rondelles doivent être jetées!

**OUTILS REQUIS**

- Clés Allen.
- Clé à cliquet + douilles.
- Clé à molette 12mm.
- Tournevis cruciforme.
- Coupe câble.

**Valeurs de serrage recommandées**

- M4 BOULON = 8Nm
- M5 BOULON = 12Nm
- M6 BOULON = 15Nm
- M8 BOULON = 20Nm
- M10 BOULON = 40Nm



Photo 1



Photo 2



Photo 3



Photo 4

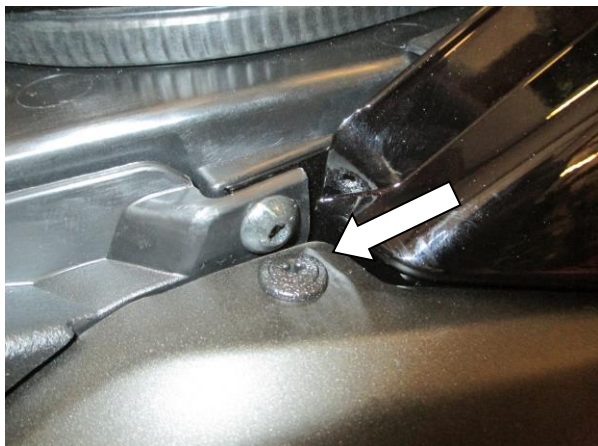

Photo 5



Photo 6



Photo 7



Photo 8



Photo 9



Photo 10



Photo 11

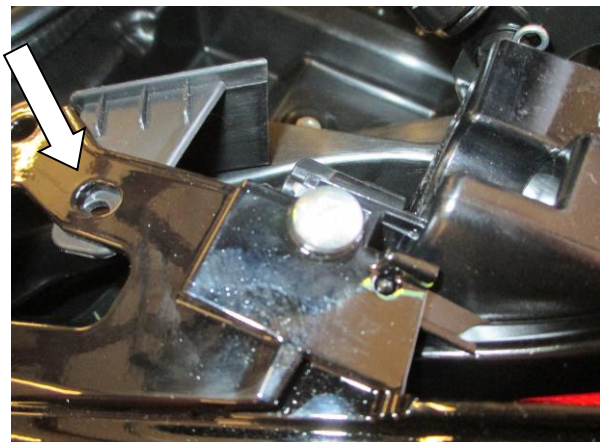

Photo 12



Photo 13



Photo 14



Photo 15



Photo 16



Photo 17



Photo 18

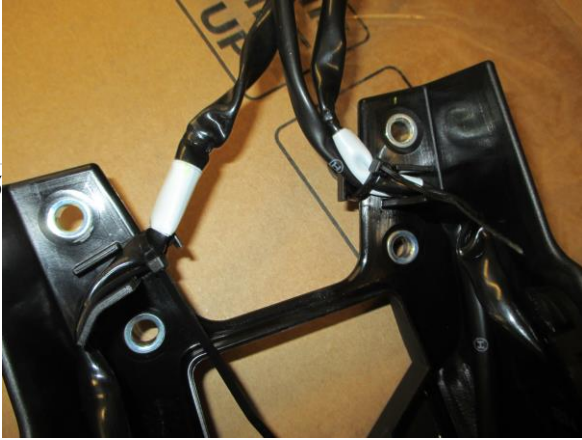

Photo 19



Photo 20



Photo 21



Photo 22



Photo 23



Photo 24

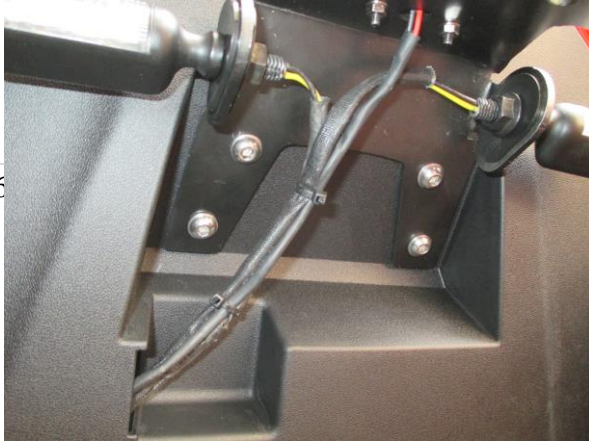

Photo 25



Photo 26

### **NOTICE DE MONTAGE**

- Pour monter le support de plaque R&G, lever le siège.
- Enlever les 2 caches plastique sur le rail de main du côté gauche de la moto, voir photo 1, puis enlever les 2 boulons au-dessous. Enlever le rail de main de la moto.
- Sur le contour plastique arrière, lever le coin du cache en caoutchouc pour accéder au boulon par dessous, voir photo 2. Enlever ce boulon, avec celui du côté droit, avant d'enlever le panneau indiqué sur la photo 3.
- Le panneau latéral large coloré indiqué sur la photo 4 doit maintenant être enlevé. Pour cela, Enlever l'attache rapide en plastique indiquée sur la photo 5, avec le boulon cache derrière la cheville de repose pied passager, voir photo 6, et les 2 boulons indiqués sur la photo 7. Une fois toutes les attaches enlevées, tirer délicatement le panneau de la moto, en libérant le support caoutchouc vers l'arrière puis enlevez le de la moto.
- Enlever le boulon qui est maintenant exposé et qui tient le carénage arrière en place contre l'avant du siège, voir photo 8.
- Enlever les 4 rivets qui fixent le panneau interne au carénage, voir photos 9, 10 & 11.
- Enlever le boulon et le rivet qui fixent l'arrière du carénage en place, voir photo 12.
- Enlever le boulon qui se situe à côté du trou de fixation en caoutchouc, voir photo 13.
- Le panneau latéral indiqué sur la photo 14 peut maintenant être enlevé de la moto en le tirant.
- L'accès est maintenant possible aux connecteurs de fils de plaque et de clignotant. Déconnecter le connecteur noir large ainsi que le connecteur blanc large, avec les 2 connecteurs, voir photo 15.
- Au-dessous du support de plaque d'origine, Enlever les 4 boulons, voir photo 16. Supporter le support tout en passant le fil à l'extérieur puis enlevez le de la moto, voir photo 17.
- Prendre le support de plaque R&G (article 2 – TB0233) et montez le feu de plaque R&G (article 1 – LA0002) sur le support, voir photo 18. Placez un manchon thermo rétractable sur les fils, serrer les écrous à l'arrière et utiliser un peu de super glue pour fixer le linceul de feu en place.

### ***Si vous montez des mini clignotants***

- Pour monter les mini clignotants R&G, appliquez une longueur de manchon thermos rétractable sur les fils de chaque clignotant.
- Passer les fils de clignotants dans le trou d'un des adaptateurs de mini clignotant (article 3 – I0016), en veillant à ce que le patron relevé sur les adaptateurs soit face à l'autre clignotant.
- Passer le fil de clignotants dans le trou du support de plaque, en positionnant le patron relevé sur l'adaptateur dans le trou, avant de positionner un 2e adaptateur de mini clignotant (article 3 – I0016) (avec la patron face au

R&G Racing

Unit 1, Shelley's Lane, East Worldham, Alton, Hampshire, GU34 3AQ

Tel: +44 (0)1420 89007 Fax: +44 (0)1420 87301 [www.rg-racing.com](http://www.rg-racing.com) Email: [info@rg-racing.com](mailto:info@rg-racing.com)





clignotant) sur le fil et dans le trou du support, avant d'insérer un écrou de clignotant sur le fil et de serrer sur la tige filetée du clignotant, voir photo 23.

- Monter l'autre clignotants de la même façon sur le support de clignotants restant en veillant à ce que le logo R&G soit orienté vers le haut.

***Si vous montez les clignotants d'origine***

- Commencez par enlever les clignotants d'origine du support de plaque d'origine. Couper les 2 clips câble, voir photo 19, avant d'enlever la pièce plastique du support en caoutchouc du clignotant. Une fois enlevée, tirer le support en caoutchouc du trou en plastique puis passer le clignotant et le fil hors du support de plaque d'origine, voir photo 20.
- Placer un des adaptateurs de clignotants d'origine (article 4 – I0037) sur le support de clignotants d'origine, voir 21.
- Monter chaque clignotant sur le support de clignotants R&G en passant le fil de clignotants dans le trou large du support de plaque puis placer le caoutchouc avec le trou, avant de remonter la plaque en plastique pour fixer la position, voir photo 22.
- Une fois les clignotants correctement montés, router le fil avec le fil de feu de plaque en utilisant des colliers de serrage fournis, voir photo 23.
- Prendre l'assemblage de support de plaque et montez le au-dessous du support tout en passant les 3 sets de fils dans le petit trou d'où le fil d'origine s'échappe, voir photo 24.
- Prendre les 4 boulons M6 x 16mm (article 5) et 4 rondelles M6 (article 6) puis placez-les dans les 4 trous de fixation du support de plaque avant de serrer dans les patrons filetés du sous-cadre, voir photo 25.
- Connecter le fil de feu de plaque aux connecteurs d'origine en utilisant les connecteurs déjà montés.
- Si vous utilisez les clignotants d'origine, reconnecter les connecteurs à ceux du faisceau principal.
- Si vous montez les mini clignotants, le fil des clignotants d'origine doit être "coupé & fermé" pour réutiliser les connecteurs de fils. Pour cela, couper le connecteur de chaque clignotant à environ 100mm de fil. Dénudez l'extrémité du fil puis monter les connecteurs femelles fournis (article 11) sur l'extrémité du fil et il peut donc à présent être connecté aux connecteurs sur les mini clignotants.
- Si un feu ne s'éclaire pas, reconnecter les connecteurs dans l'autre sens.
- Vérifier que l'ensemble des feux fonctionnent.
- Veiller à ce que le fil soit correctement range derrière le panneau, voir photo 26.
- Remonter les 3 pièces de carénage et les rails de main en réalisant la procédure inverse de la façon dont ils ont été enlevés.
- Réinstaller la plaque (peut nécessiter un perçage).
- Selon les lois locales, attacher le réflecteur rouge (article 13) à l'endroit approprié.
- **Tester le feu de plaque, les clignotants, ainsi que l'ensemble des feux avant de prendre la route.**

ISSUE 1 31/08/2017 (AR)

**Notice disponible au téléchargement sur [www.rg-racing.com](http://www.rg-racing.com)**

**CONSUMER NOTICE**

The catalogue description and any exhibition of samples are only broad indications of the Products and R&G may make design changes which do not diminish their performance or visual appeal and supplying them in such state shall conform to the order. The Buyer acknowledges no representation or warranty (other than as to title) has been given or will apply to the Products other than those in R&G's order or confirmation and the Buyer confirms it has chosen the Products as being of merchantable quality and suitable for its particular purposes. Where R&G fits the Products or undertakes other services it shall exercise reasonable skill and care and rectify any fault free of charge unless the workmanship has been disturbed. The Buyer is responsible for ensuring that the warranty on the motorcycle is not affected by the fitting of the Products. On return of any defective Products R&G shall at its option either supply a replacement or refund the purchase money but shall not be liable if the Products have been modified or used or maintained otherwise than in accordance with R&G's or manufacturer's instructions and good engineering practice or if the defect arises from accident or neglect. Other than identified above and subject to R&G not limiting its liability for causing death and personal injury, it shall not be liable for

R&G Racing

Unit 1, Shelley's Lane, East Worldham, Alton, Hampshire, GU34 3AQ

Tel: +44 (0)1420 89007 Fax: +44 (0)1420 87301 [www.rg-racing.com](http://www.rg-racing.com) Email: [info@rg-racing.com](mailto:info@rg-racing.com)



indirect or consequential loss and otherwise its liability shall be limited to the amounts paid by the Buyer for the Products or the fitting or service concerned. These terms do not affect the Buyer's statutory rights.

**R&G RACING RETURNS POLICY (NON-FAULTY GOODS)**

Returns must be pre-authorized (if not pre-authorized the return will be rejected). Goods may only be returned direct to us if they were purchased direct from us (customer must prove if necessary). Otherwise to be returned to original vendor. Goods must be in re-sellable condition, in the opinion of R&G Racing. All returns are subject to a 25% restocking and handling fee (25% of the gross value exc. P&P – at the prevailing price at time of purchase). The customer must pay any and all carriage charges. No returns of discontinued products, unless within 14 days of purchase. This policy does not affect your statutory rights and does not refer to faulty goods.