



**FITTING INSTRUCTIONS FOR CP0398BL/WH NO-CUT AERO CRASH
PROTECTORS
MV AGUSTA F4-RC 2015- MODELS**

Page | 1



PICTURE 'A'



PICTURE 'B'



REAR OF BIKE

FRONT OF BIKE

PICTURE 'C'

**THIS KIT CONTAINS THE ITEMS PICTURED AND LABELLED BELOW.
DO NOT PROCEED UNTIL YOU ARE SURE ALL PARTS ARE PRESENT.**

Please note that the way the kit is packed does not necessarily represent the way of mounting to the bike

Please note that in cases where kits are packed with rubber washers holding the components onto the bolt – *the rubber washers should be thrown away!*

THE PARTS SHOWN MAY BE REPRESENTATIVE ONLY (FOR CLARITY OF INSTRUCTIONS ONLY)

Digital copies of these instructions are available to download from www.rg-racing.com

GENERAL TORQUE SETTINGS

M4 BOLT = 8Nm
M5 BOLT = 12Nm
M6 BOLT = 15Nm
M8 BOLT = 20Nm
M10 BOLT = 40Nm

R&G Racing

Unit 1 Shelleys Lane, East Worldham, Alton, Hants GU34 3AQ

Tel: +44 (0)1420 89007 Fax: +44 (0)1420 87301 www.rg-racing.com Email: info@rg-racing.com

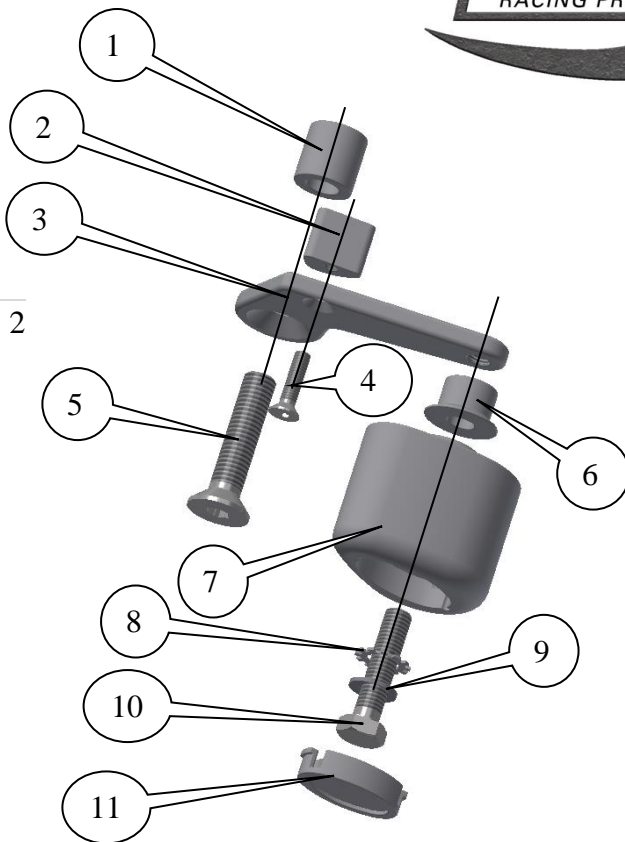
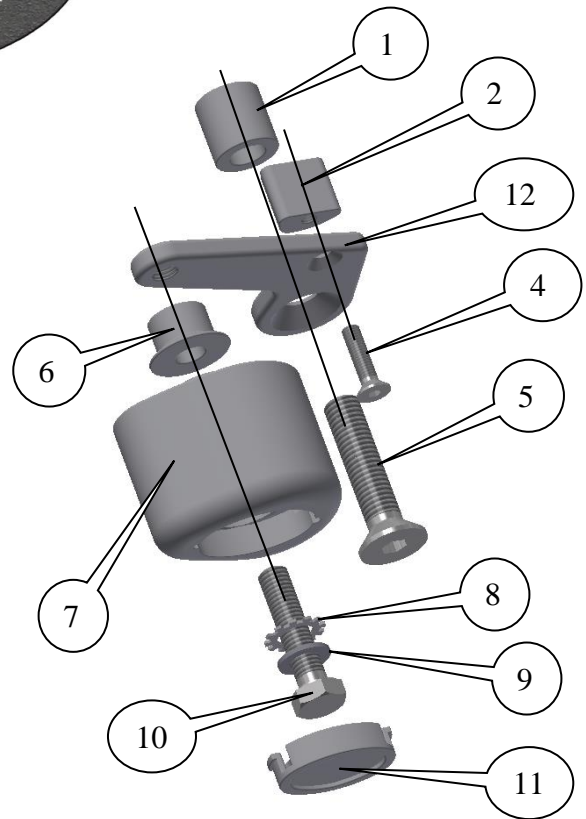
LEFT HAND SIDE ASSEMBLYRIGHT HAND SIDE ASSEMBLY**TOOLS REQUIRED**

- Socket set to include 14 and 17mm A/F socket and wrench.
- Hex drive bits or set of Allen keys to include 4 and 6mm A-F.
 - Torque wrench (up to 40Nm).

LEGEND

- ITEM 1 = MOUNTING PLATE SPACERS, L&RHS (S0938=22mm WIDE) (x2).
 ITEM 2 = ANTI-ROTATION SPACERS, L&RHS (M0471) (x2).
 ITEM 3 = MOUNTING PLATE LHS (M0472) (x1).
 ITEM 4 = M6x25mm LONG COUNTER-SUNK BOLT, L&RHS (x2).
 ITEM 5 = M12x55mm LONG COUNTER-SUNK BOLT, L&RHS (x2).
 ITEM 6 = CRASH PROTECTOR SPACERS, L&RHS (S0937=15mm WIDE) (x2).
 ITEM 7 = CRASH PROTECTORS, L&RHS (B0063 with CS066, 10mm) (x2).
 ITEM 8 = LOCKING WASHERS, L&RHS (LW0001) (x2).
 ITEM 9 = M10 PLAIN WASHERS, L&RHS (x2).
 ITEM 10 = CRASH PROTECTOR BOLTS, L&RHS, M10x45mm LONG HEX HEAD (x2).
 ITEM 11 = CRASH PROTECTOR CAPS, L&RHS (BC0002) (x2).
 ITEM 12 = MOUNTING PLATE RHS (M0473) (x1).

R&G Racing

Unit 1 Shelleys Lane, East Worldham, Alton, Hants GU34 3AQ

Tel: +44 (0)1420 89007 Fax: +44 (0)1420 87301 www.rg-racing.com Email: info@rg-racing.com



PICTURE 1



PICTURE 2



PICTURE 3



PICTURE 4

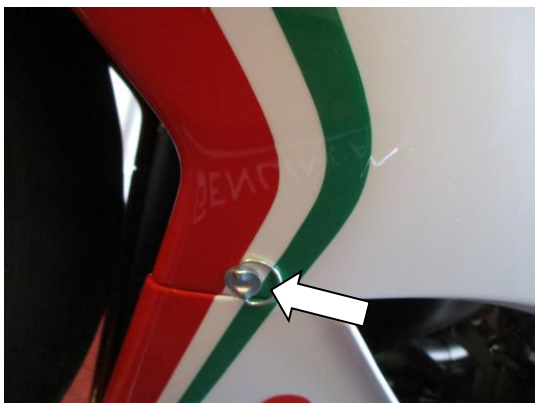

PICTURE 5



PICTURE 6

R&G Racing

Unit 1 Shelleys Lane, East Worldham, Alton, Hants GU34 3AQ

Tel: +44 (0)1420 89007 Fax: +44 (0)1420 87301 www.rg-racing.com Email: info@rg-racing.com

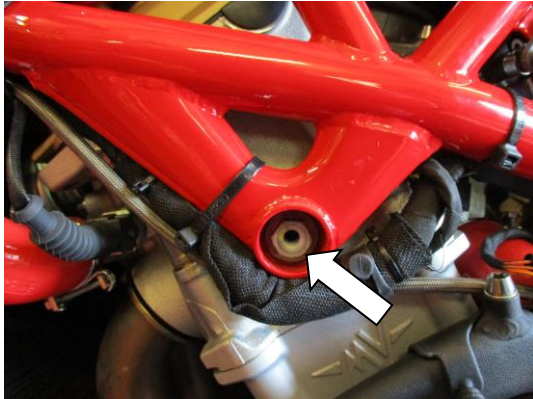

PICTURE 7



PICTURE 8



PICTURE 9



PICTURE 10

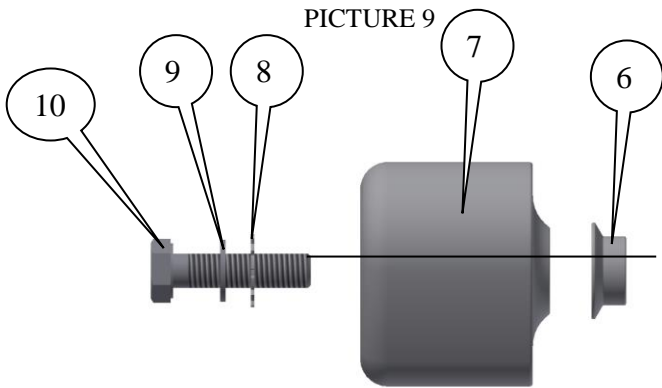

PICTURE 11



PICTURE 12

R&G Racing

Unit 1 Shelleys Lane, East Worldham, Alton, Hants GU34 3AQ

Tel: +44 (0)1420 89007 Fax: +44 (0)1420 87301 www.rg-racing.com Email: info@rg-racing.com



PICTURE 13



PICTURE 14



PICTURE 15

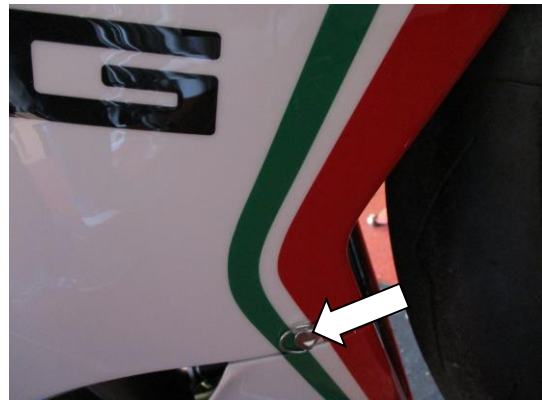

PICTURE 16



PICTURE 17



PICTURE 18

R&G Racing

Unit 1 Shelleys Lane, East Worldham, Alton, Hants GU34 3AQ

Tel: +44 (0)1420 89007 Fax: +44 (0)1420 87301 www.rg-racing.com Email: info@rg-racing.com

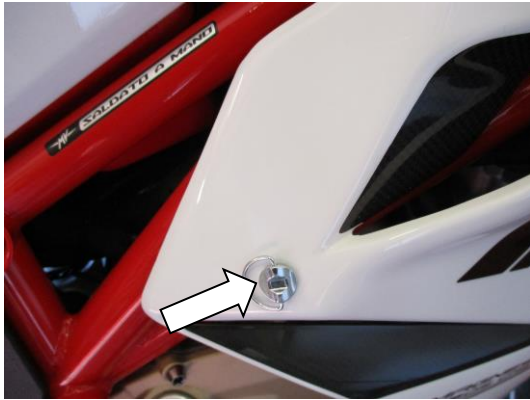

PICTURE 19

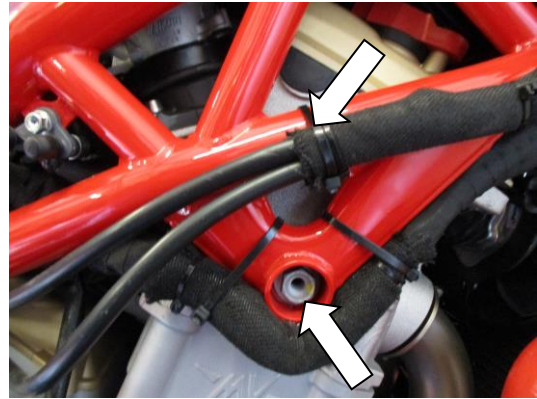

PICTURE 20



PICTURE 21



PICTURE 22



PICTURE 23

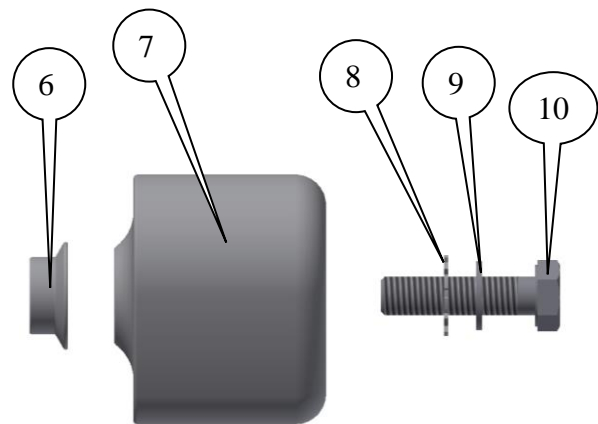

PICTURE 24

R&G Racing

Unit 1 Shelleys Lane, East Worldham, Alton, Hants GU34 3AQ

Tel: +44 (0)1420 89007 Fax: +44 (0)1420 87301 www.rg-racing.com Email: info@rg-racing.com



PICTURE 25



PICTURE 26

FITTING INSTRUCTIONS

Near side (left side as you sit on bike)

- Remove the seven quarter turn fasteners arrowed in pictures 1, 2, 3, 4, 5 and 6 and remove the left hand side fairing.
- Remove the bolt in position arrowed in picture 7.
- Place one of the larger counter-sunk bolts (item 10, M12x55mm long) into the left hand side mounting plate (item 3) as shown in pictures 8 and 9 (and the assembly drawing), place one of the larger spacers (item 1) over the exposed end of the bolt as shown in picture 8 and 9.
- Place one of the smaller counter-sunk bolts (item 4, M6x25mm long) into the left hand side mounting plate (item 3) as shown in pictures 8 and 9 (and the assembly drawing), place one of the shaped threaded anti-rotation spacers (item 2) onto the exposed thread of the bolt as shown in pictures 8 and 9 (do not fully tighten at this stage).
- Offer this assembly into position as shown in picture 10 (the larger spacer goes into the frame recess) while ensuring the anti-rotation spacer fits snugly into the frame and tighten both bolts.
- Refit the left hand side fairing as original (as the fairing are close to the mounting bracket care must be taken when fitting).
- Place one of the M10 washers (item 9) onto the one of the M10 bolts (item 10) as shown in picture 11.
- Place one of the locking washers (item 8) onto the bolt so it sits against the washer just fitted as shown in picture 11.
- Place the bolt with both washers into the crash protector (item 7) as shown in picture 11.
- Place one of the stepped spacers (item 6) over the exposed end of the bolt so larger the larger end sits against the crash protector as shown in picture 11.
- Offer this assembly into the threaded hole in the mounting plate as shown in picture 12 (care must be taken so as to cause no damage to the fairing). Please ensure no parts come in contact with any fairing panels. Finally tighten the crash protector bolts until you feel some compression from inside the protector using 17mm socket and wrench. **PLEASE NOTE THE CRASH PROTECTOR MUST BE POSITIONED AS IN PICTURE 'C' WITH BIGGER END TOWARD FRONT OF BIKE.** Turn a little more so that you feel the compression increase slightly. Then apply a quarter turn. Do not over tighten as damage can occur to the bike. Do not exceed 40 N/m of torque.
- If not already fitted, fit bubble sticker into recess of crash protector cap (item 11).
- Fit crash protector cap (item 11) into the crash protector.

R&G Racing

Unit 1 Shelleys Lane, East Worldham, Alton, Hants GU34 3AQ

Tel: +44 (0)1420 89007 Fax: +44 (0)1420 87301 www.rg-racing.com Email: info@rg-racing.com



Off side (right side as you sit on bike)

- Remove the seven quarter turn fasteners arrowed in pictures 13, 14, 15, 16, 17, 18 and 19 and remove the right hand side fairing.
- Remove the bolt in position arrowed in picture 20.
- Remove the upper cable tie arrowed in picture 20 and reposition the two cables as shown in picture 23 (please ensure when the forks are at full lock in both directions the cable are free and operate correctly).
- Place the remaining larger counter-sunk bolt (item 10, M12x55mm long) into the right hand side mounting plate (item 12) as shown in pictures 21 and 22 (and the assembly drawing), place the remaining larger spacer (item 1) over the exposed end of the bolt as shown in picture 21 and 22.
- Place the remaining smaller counter-sunk bolt (item 4, M6x25mm long) into the right hand side mounting plate (item 12) as shown in pictures 21 and 22 (and the assembly drawing), place the remaining shaped threaded anti rotation spacers (item 2) onto the exposed thread of the bolt as shown in pictures 21 and 22 (do not fully tighten at this stage).
- Offer this assembly into position as shown in picture 23 (the larger spacer goes into the frame recess) while ensuring the anti-rotation spacer fits snugly into the frame and tighten both bolts.
- Refit the right hand side fairing as original (as the fairing are close to the mounting bracket care must be taken when fitting).
- Place the remaining M10 washer (item 9) onto the remaining M10 bolt (item 10) as shown in picture 24.
- Place the remaining locking washer (item 8) onto the bolt so it sits against the washer just fitted as shown in picture 24.
- Place the bolt with both washers into the crash protector (item 7) as shown in picture 24.
- Place the remaining stepped spacer (item 6) over the exposed end of the bolt so larger the larger end sits against the crash protector as shown in picture 24.
- Offer this assembly into the threaded hole in the mounting plate as shown in picture 25 (care must be taken so as to cause no damage to the fairing). Please ensure no parts come in contact with any fairing panels. Finally tighten the crash protector bolts until you feel some compression from inside the protector using 17mm socket and wrench. **PLEASE NOTE THE CRASH PROTECTOR MUST BE POSITIONED AS IN PICTURE 'C' WITH BIGGER END TOWARD FRONT OF BIKE.** Turn a little more so that you feel the compression increase slightly. Then apply a quarter turn. Do not over tighten as damage can occur to the bike. Do not exceed 40 N/m of torque.
- If not already fitted, fit bubble sticker into recess of crash protector cap (item 11).
- Fit crash protector cap (item 11) into the crash protector.

ISSUE 1 20/04/2016 (NSY)

CONSUMER NOTICE

The catalogue description and any exhibition of samples are only broad indications of the Products and R&G may make design changes which do not diminish their performance or visual appeal and supplying them in such state shall conform to the order. The Buyer acknowledges no representation or warranty (other than as to title) has been given or will apply to the Products other than those in R&G's order or confirmation and the Buyer confirms it has chosen the Products as being of merchantable quality and suitable for its particular purposes. Where R&G fits the Products or undertakes other services it shall exercise reasonable skill and care and rectify any fault free of charge unless the workmanship has been disturbed. The Buyer is responsible for ensuring that the warranty on the motorcycle is not affected by the fitting of the Products. On return of any defective Products R&G shall at its option either supply a replacement or refund the purchase money but shall not be liable if the Products have been modified or used or maintained otherwise than in accordance with R&G's or manufacturer's instructions and good engineering practice or if the defect arises from accident or neglect. Other than identified above and subject to R&G not limiting its liability for causing death and personal injury, it shall not be liable for indirect or consequential loss and

R&G Racing

Unit 1 Shelleys Lane, East Worldham, Alton, Hants GU34 3AQ

Tel: +44 (0)1420 89007 Fax: +44 (0)1420 87301 www.rg-racing.com Email: info@rg-racing.com



otherwise its liability shall be limited to the amounts paid by the Buyer for the Products or the fitting or service concerned. These terms do not affect the Buyer's statutory rights.

R&G RACING RETURNS POLICY (NON-FAULTY GOODS)

Returns must be pre-authorised (if not pre-authorised the return will be rejected). Goods may only be returned direct to us if they were purchased direct from us (customer must prove if necessary). Otherwise to be returned to original vendor. Goods must be in re-sellable condition, in the opinion of R&G Racing. All returns are subject to a 25% restocking and handling fee (25% of the gross value exc. P&P – at the prevailing price at time of purchase). The customer must pay any and all carriage charges. No returns of discontinued products, unless within 14 days of purchase. This policy does not affect your statutory rights and does not refer to faulty goods.



NOTICE DE MONTAGE CP0398BL/WH PROTECTIONS CRASH LATERALES
NON COUPEES
MV AGUSTA F4-RC 2015- MODELES

Page | 10



PHOTO 'A'



PHOTO 'B'



LE KIT CONTIENT LES ARTICLES EXPOSES CI-DESSOUS, VERIFIER QUE TOUTES LES PIECES SOIENT PRESENTES AVANT DE PROCEDER AU MONTAGE.

LA FAÇON DONT LE KIT EST EMBALLE NE CORRESPOND PAS FORCEMENT A LA FAÇON DE MONTER LES PIECES SUR LA MOTO.

Notez que si les kits sont emballés avec des rondelles en caoutchouc servant à tenir les composants, *ces rondelles doivent être jetées!*

LES PARTIES PRESENTEES PEUVENT ETRE UNIQUEMENT REPRESENTATIVES (POUR LA CLARTE DES INSTRUCTIONS UNIQUEMENT.

Notice disponible au téléchargement sur www.rg-racing.com

R&G Racing

Unit 1 Shelleys Lane, East Worldham, Alton, Hants GU34 3AQ
 Tel: +44 (0)1420 89007 Fax: +44 (0)1420 87301 www.rg-racing.com Email: info@rg-racing.com



COUPLES DE SERRAGE RECOMMANDES

M4 BOULON = 8Nm
 M5 BOULON = 12Nm
 M6 BOULON = 15Nm
 M8 BOULON = 20Nm
 M10 BOULON = 40Nm

Page | 11

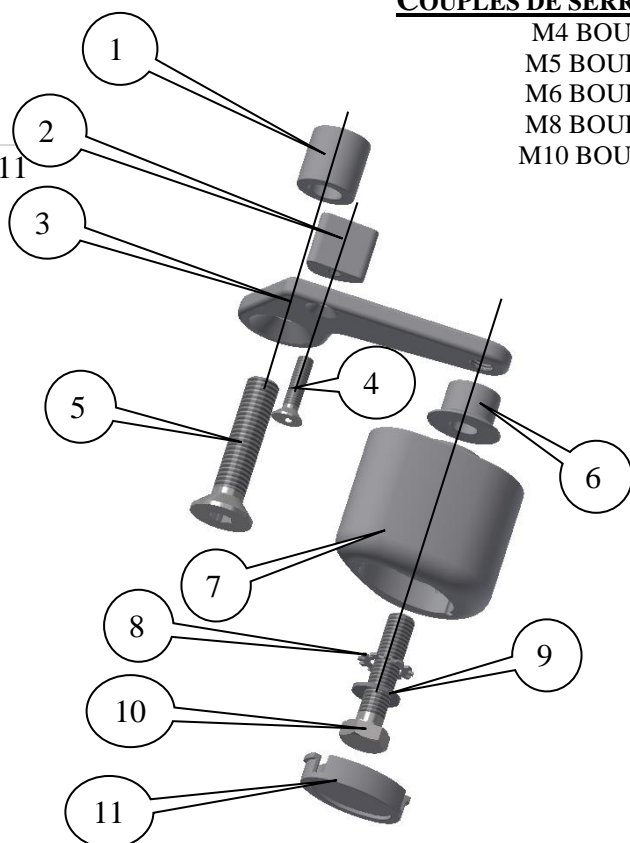

ASSEMBLAGE COTE GAUCHE

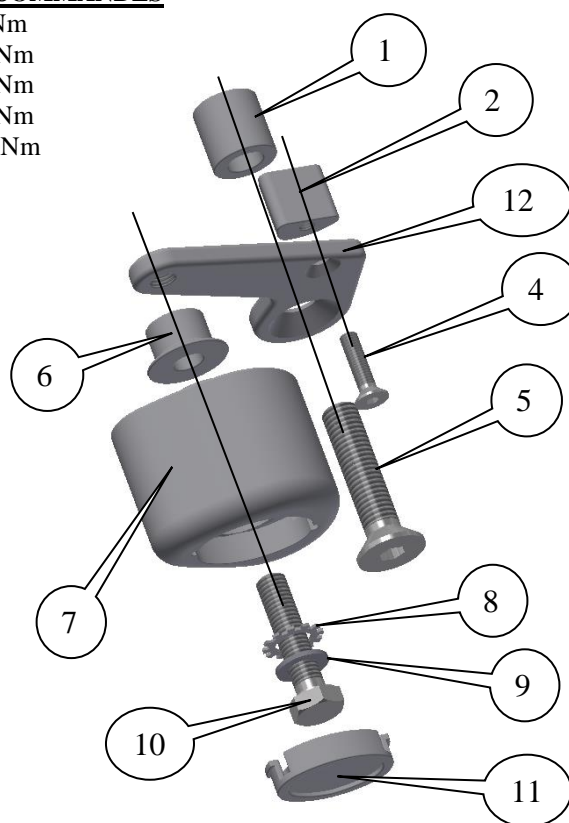

ASSEMBLAGE COTE DROIT

OUTILS REQUIS

- Clés à cliquet 14 et 17mm.
- Clés Allen 4 et 6mm.
- Clé dynamométrique (à 40Nm).

LEGENDE

ARTICLE 1 = ENTRETOISES DE PLAQUE DE FIXATION, GAUCHE ET DROITE (S0938=22mm DE LARGE) (x2).

ARTICLE 2 = ENTRETOISES ANTI ROTATION, GAUCHE ET DROITE (M0471) (x2).

ARTICLE 3 = PLAQUE DE FIXATION GAUCHE (M0472) (x1).

ARTICLE 4 = BOULON M6x25mm, GAUCHE ET DROITE (x2).

ARTICLE 5 = BOULON M12x55mm, GAUCHE ET DROITE (x2).

ARTICLE 6 = ENTRETOISES DE PROTECTION CRASH, GAUCHE ET DROITE (S0937=15mm DE LARGE) (x2).

ARTICLE 7 = PROTECTIONS CRASH, GAUCHE ET DROITE (B0063 avec CS066, 10mm) (x2).

ARTICLE 8 = RONDELLES DE BLOCAGE, GAUCHE ET DROITE LW0001) (x2).

R&G Racing

Unit 1 Shelleys Lane, East Worldham, Alton, Hants GU34 3AQ

Tel: +44 (0)1420 89007 Fax: +44 (0)1420 87301 www.rg-racing.com Email: info@rg-racing.com



ARTICLE 9 = RONDELLES M10, GAUCHE ET DROITE (x2).

ARTICLE 10 = BOULONS DE PROTECTION CRASH, GAUCHE ET DROITE M10x45mm (x2).

ARTICLE 11 = CAPUCHONS DE PROECTION, GAUCHE ET DROITE (BC0002) (x2).

ARTICLE 12 = PLAQUE DE FIXATION COTE DROIT (M0473) (x1).

Page | 12 NOTICE DE MONTAGE

Coté gauche (assis sur la moto)

- Enlever les 7 attaches rapides, voir photos 1, 2, 3, 4, 5 et 6 puis le carénage coté gauche.
- Enlever le boulon indiqué sur la photo 7.
- Placer un des boulons (article 10, M12x55mm de long) dans la plaque de fixation du coté gauche (article 3) voir photos 8 et 9 (et le dessin d'assemblage), placer une des entretoises larges (article 1) sur l'extrémité du boulon, voir photos 8 et 9.
- Placer un des boulons (article 4, M6x25mm de long) dans la plaque de fixation du coté gauche (article 3) voir photos 8 et 9 (et le dessin d'assemblage), placer une des entretoises anti rotation (article 2) sur l'extrémité du filetage du boulon, voir photos 8 et 9 (Ne pas serrer complètement pour le moment).
- Monter l'ensemble en position, voir photo 10 (l'entretoise la plus large se place dans le creux du cadre) tout en veillant à ce que l'entretoise anti rotation se place dans le cadre puis serrer les boulons.
- Remettre le carénage du coté gauche comme à l'origine (Veiller à ne pas abîmer le carénage).
- Placer une des rondelles M10 (article 9) sur un des boulons M10 (article 10) voir photo 11.
- Placer une des rondelles de blocage (article 8) sur le boulon de façon à ce qu'il se place contre la rondelle tout juste insérée, voir photo 11.
- Placer le boulon avec les 2 rondelles dans la protection crash (article 7) voir photo 11.
- Placer une des entretoises (article 6) sur l'extrémité du boulon de façon à ce que la partie plus large se place contre la protection crash, voir photo 11.
- Monter l'ensemble dans le trou fileté de la plaque de fixation, voir photo 12 (Veiller à ne pas abîmer le carénage). Veiller à ce qu'aucune partie ne puisse entrer en contact avec le carénage. Enfin, serrer les boulons de protection crash jusqu'à ce que vous sentiez la compression s'accroître dans la protection, en utilisant une pince de 17mm. **LA PROTECTION DOIT ETRE POSITIONNEE COMME EN "C" AVEC LE COTE ARRONDI LE PLUS GROS EN DIRECTION DE L'AVANT DE LA MOTO.** Tourner un peu plus afin d'accroître légèrement la compression. Faire un quart de tour. Pas plus de 40 Nm de couple - Ne pas trop serrer, au risque d'abîmer les composants.
- Placer le sticker R&G dans le creux de capuchon de la protection (article 11).
- Insérer le capuchon de la protection (article 11) dans la protection crash.

Coté droit (assis sur la moto)

- Enlever les 7 attaches rapides, voir photos 13, 14, 15, 16, 17, 18 et 19 puis le carénage coté droit.
- Enlever le boulon indiqué sur la photo 20.
- Enlever le collier de serrage supérieur, voir photo 20 et repositionner les 2 câbles, voir photo 23 (Veillez à ce les cables soient opérationnels lorsque les fourches sont sollicitées au maximum dans les 2 directions).
- Placer le boulon restant (article 10, M12x55mm de long) dans la plaque de fixation du coté droit (article 12) voir photos 21 et 22 (et le dessin d'assemblage), placer l'entretoise large restante (article 1) sur l'extrémité du boulon, voir photo 21 et 22.
- Placer le boulon restante (article 4, M6x25mm de long) dans le plaque de fixation du coté droit (article 12) voir photos 21 et 22 (et le dessin d'assemblage), placer les entretoises anti rotation restantes (article 2)

R&G Racing

Unit 1 Shelleys Lane, East Worldham, Alton, Hants GU34 3AQ

Tel: +44 (0)1420 89007 Fax: +44 (0)1420 87301 www.rg-racing.com Email: info@rg-racing.com



2) sur l'extrémité du filetage du boulon, voir photos 21 et 22 (Ne pas serrer complètement pour le moment).

- Monter l'ensemble en position, voir photo 23 (l'entretoise plus large se place dans le creux de cadre) tout en veillant à ce que l'entretoise anti rotation se place dans le cadre puis serrer les 2 boulons.
- Remonter le carénage du coté droit comme à l'origine (Veiller à ne pas abimer le carénage).
- Placer la rondelle 10 restante (article 9) sur le boulon M10 restant (article 10) voir photo 24.
- Placer la rondelle de blocage restante (article 8) sur le boulon de façon à ce qu'elle se place sur la rondelle tout juste insérée, voir photo 24.
- Placer le boulon avec les 2 rondelles dans la protection crash (article 7) voir photo 24.
- Placer l'entretoise restante (article 6) sur l'extrémité du boulon de façon à ce que la partie plus large du boulon se place contre la protection crash, voir photo 24.
- Monter l'ensemble sur le trou fileté de la plaque de fixation, voir photo 25 (Veiller à ne pas abimer le carénage). Veiller à ce qu'aucune partie ne puisse entrer en contact avec le carénage. Enfin, serrer les boulons de protection crash jusqu'à ce que vous sentiez la compression s'accroître dans la protection, en utilisant une pince de 17mm. **LA PROTECTION DOIT ETRE POSITIONNEE COMME EN "C" AVEC LE COTE ARRONDI LE PLUS GROS EN DIRECTION DE L'AVANT DE LA MOTO.** Tourner un peu plus afin d'accroître légèrement la compression. Faire un quart de tour. Pas plus de 40 Nm de couple - Ne pas trop serrer, au risque d'abimer les composants.
- Placer le sticker R&G dans le creux de capuchon de la protection (article 11).
- Insérer le capuchon de la protection (article 11) dans la protection crash.

ISSUE 1 20/04/2016 (NSY)

CONSUMER NOTICE

The catalogue description and any exhibition of samples are only broad indications of the Products and R&G may make design changes which do not diminish their performance or visual appeal and supplying them in such state shall conform to the order. The Buyer acknowledges no representation or warranty (other than as to title) has been given or will apply to the Products other than those in R&G's order or confirmation and the Buyer confirms it has chosen the Products as being of merchantable quality and suitable for its particular purposes. Where R&G fits the Products or undertakes other services it shall exercise reasonable skill and care and rectify any fault free of charge unless the workmanship has been disturbed. The Buyer is responsible for ensuring that the warranty on the motorcycle is not affected by the fitting of the Products. On return of any defective Products R&G shall at its option either supply a replacement or refund the purchase money but shall not be liable if the Products have been modified or used or maintained otherwise than in accordance with R&G's or manufacturer's instructions and good engineering practice or if the defect arises from accident or neglect. Other than identified above and subject to R&G not limiting its liability for causing death and personal injury, it shall not be liable for indirect or consequential loss and otherwise its liability shall be limited to the amounts paid by the Buyer for the Products or the fitting or service concerned. These terms do not affect the Buyer's statutory rights.

R&G RACING RETURNS POLICY (NON-FAULTY GOODS)

Returns must be pre-authorised (if not pre-authorised the return will be rejected). Goods may only be returned direct to us if they were purchased direct from us (customer must prove if necessary). Otherwise to be returned to original vendor. Goods must be in re-sellable condition, in the opinion of R&G Racing. All returns are subject to a 25% restocking and handling fee (25% of the gross value exc. P&P – at the prevailing price at time of purchase). The customer must pay any and all carriage charges. No returns of discontinued products, unless within 14 days of purchase. This policy does not affect your statutory rights and does not refer to faulty goods.

R&G Racing

Unit 1 Shelleys Lane, East Worldham, Alton, Hants GU34 3AQ

Tel: +44 (0)1420 89007 Fax: +44 (0)1420 87301 www.rg-racing.com Email: info@rg-racing.com