



**FITTING INSTRUCTIONS FOR LP0206BK LICENCE PLATE BRACKET**  
**HONDA MSX 125 2016-**



**THIS KIT CONTAINS THE ITEMS PICTURED AND LABELLED BELOW.**  
**DO NOT PROCEED UNTIL YOU ARE SURE ALL PARTS ARE PRESENT.**

Please note that the way the kit is packed does not necessarily represent the way of mounting to the bike.

THE PARTS SHOWN MAY BE REPRESENTATIVE ONLY (FOR CLARITY OF INSTRUCTIONS ONLY)

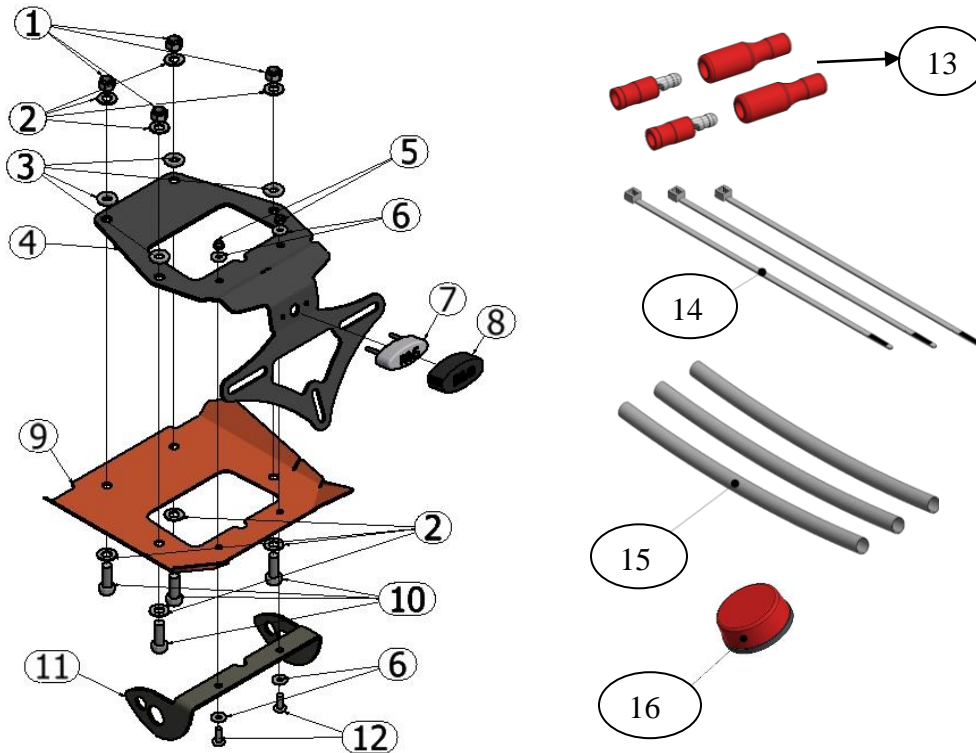



### **LEGEND**

- ITEM 1 = M8 Nyloc nuts (x4)
- ITEM 2 = M8 Washers (x8)
- ITEM 3 = Spacers (S0693) (x4)
- ITEM 4 = Licence Plate Bracket (TB0206 Part 1) (x1)
- ITEM 5 = M5 Nyloc nuts (x2)
- ITEM 6 = M5 Washers (x4)
- ITEM 7 = Licence Plate Illuminator (LA0002) (x1)
- ITEM 8 = Licence Plate Illuminator Shroud (x1)
- ITEM 9 = Cover plate (TB0206 Part 2) (x1)
- ITEM 10 = M6 x 20mm Long Button Head Bolts (x4)
- ITEM 11 = Standard Indicator Bracket (TB0206 Part 3)
- ITEM 12 = M5 x 12mm Long Button Head Bolts (x2)
- ITEM 13 = Bullet Connectors (CON004) (x1set)
- ITEM 14 = Cable Ties (x3)
- ITEM 15 = Heat Shrink Tubes (x3)
- ITEM 16 = Reflector (x1)

Please note that in cases where kits are packed with rubber washers holding the components onto the bolt – *the rubber washers should be thrown away!*

### **TOOLS REQUIRED**

- Set of metric Allen keys
- Electrical pliers/crimps
- Metric socket set to include 14mm socket and a wrench
- A 13mm open-ended spanner
- Phillips type screwdriver
- Small amount of super glue
- Small amount of grease

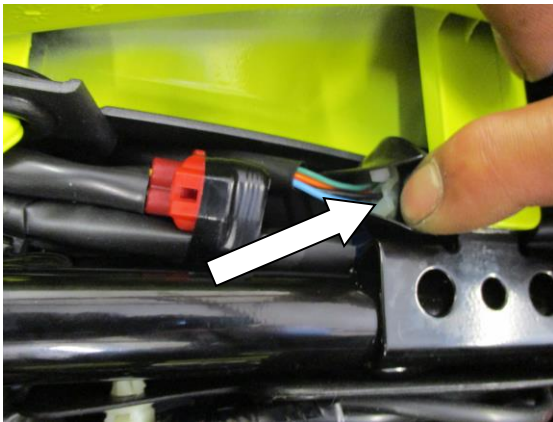

PICTURE 1

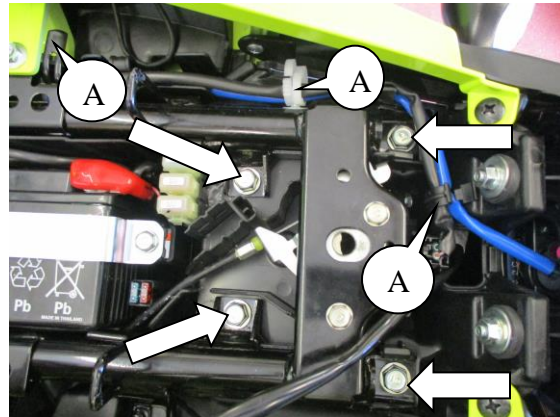

PICTURE 2

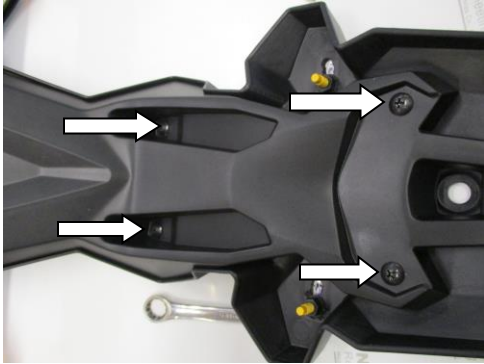

PICTURE 3

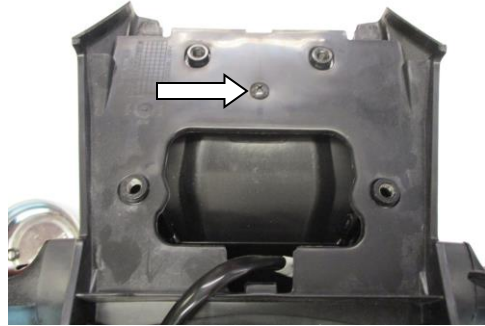

PICTURE 4

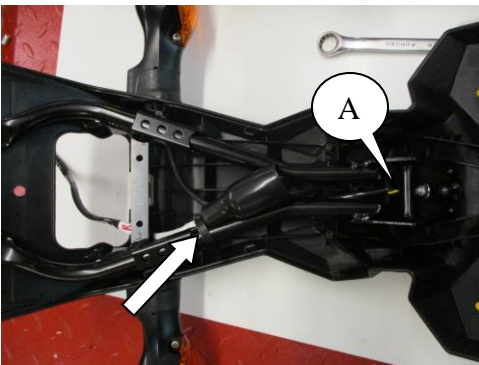

PICTURE 5

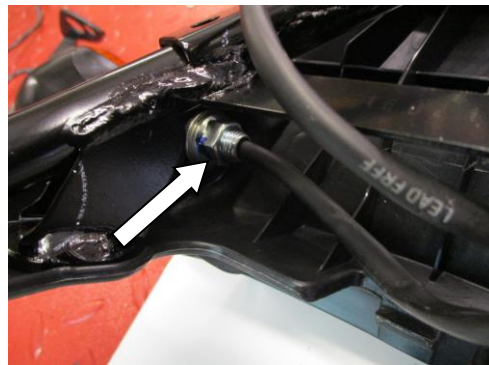

PICTURE 6

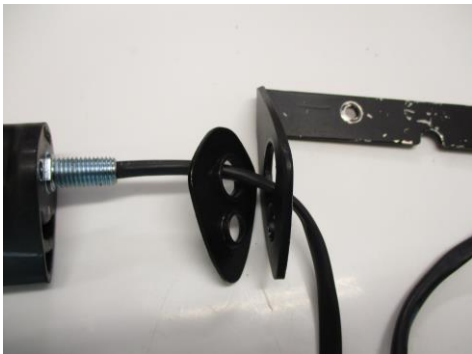

PICTURE 7

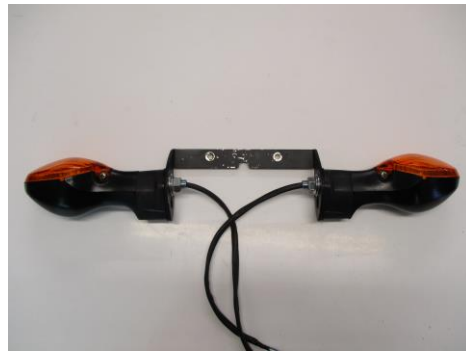

PICTURE 8



PICTURE 9

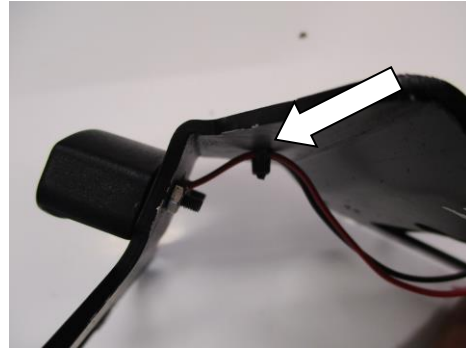

PICTURE 10

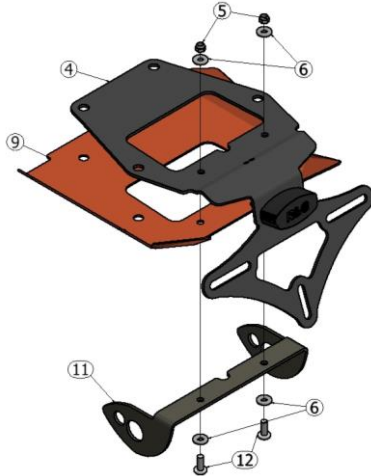

PICTURE 11

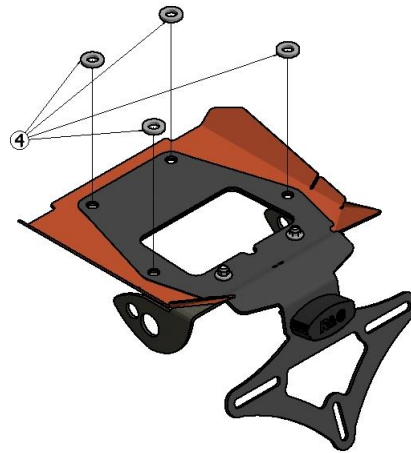

PICTURE 12



PICTURE 13

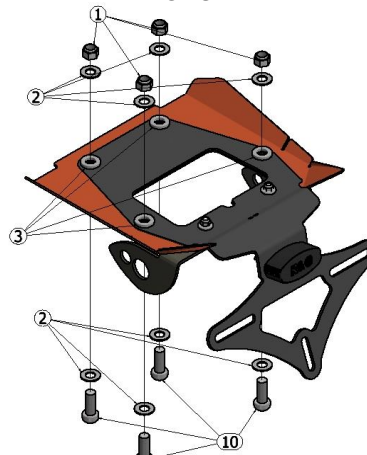

PICTURE 14



PICTURE 15

### **FITTING INSTRUCTIONS**

- Remove seat using the key.
- Disconnect the main square tail light unit connector which located on the RHS of the rear panel (as arrowed in Picture 1)
- Unclip all wiring guards as labelled A in Picture 2 and move away the tail light wiring just been disconnected.
- Remove the four bolts arrowed in Picture 2 using a 14mm socket and a wrench. Keep the tail unit supported while undoing the four bolts. Gently pull away the tail unit assembly and its wiring from the subframe of the bike and please note the orientation of the wiring.
- On the OEM tail unit, remove the four screws arrowed in Picture 3 using a phillip screwdriver.
- Remove a single screw arrowed in Picture 4 located on the other side of the tail unit using a phillip screwdriver. Once removed, gently split the tail unit in halves.
- Unclip the wiring guard arrowed in Picture 5 and disconnect the indicator connectors (please note the orientation of the connectors). Gently pull away the OEM licence plate illuminator bulb holder from its housing and remove the bulb from the holder (as labelled A in Picture 5).
- Gently remove the sub-harness from the OEM tail unit completely.
- Using an open ended 13mm spanner, remove both indicators by removing the nut arrowed in Picture 6. Please note the position of the indicator guard plate during removal.
- If using LP0206BK kit, Take the indicator bracket (Item 11) and fit both OEM indicators with the guard plate as shown in Picture 7. Secure the indicators using the OEM nuts. Finished indicator assembly is shown in Picture 8.
- From the kit, take the licence plate bracket (Item 4) and the licence plate illuminator (Item 7). Fit the licence plate illuminator (Item 7) through the three in-line holes on the licence plate bracket (Item 4) as arrowed in Picture 9 and secure using M3 washers and nuts provided in the kit. Take the Licence plate illuminator shroud (Item 8) and apply a small amount of superglue on the inside and place it over the licence plate illuminator (Item 7). Insert both red and black wires through the heat shrink tube provided in the kit and shrink the tube using a suitable heat resources.
- From the kit take one of the cable tie provided and loop it around the two small holes located in the centre of the licence plate bracket (Item 4). Secure the licence plate illuminator (Item 7) wiring with the cable tie just fitted as shown in Picture 10.
- From the kit, take the cover plate (Item 9) and place it below the licence plate bracket (Item 4). Ensure that the folded areas of the cover plate are facing upwards. Align all the 5mm and 8mm holes together.

R&G Racing

Unit 1, Shelley's Lane, East Worldham, Alton, Hampshire, GU34 3AQ

Tel: +44 (0)1420 89007 Fax: +44 (0)1420 87301 [www.rg-racing.com](http://www.rg-racing.com) Email: [info@rg-racing.com](mailto:info@rg-racing.com)



- Take the indicator bracket assembly and position it below the cover plate with both 5mm holes being aligned as shown in Picture 11. Secure the assembly using M5 bolts (Item 12) with M5 washers (Item 6) and M5 nyloc nuts (Item 5) from the kit. Tighten the nuts to 12Nm.
  - Apply a thin layer of grease onto the surface of each spacer (Item 3) provided in the kit. Place each spacer over the 8mm hole on the licence plate bracket (Item 4). Shown in Picture 12. The grease is used to keep the spacers in place while fitting.
  - Offer the whole tail tidy assembly towards the subframe of the bike with all the wires being positioned in the slot provided (shown in Picture 13). Locate the wires around the subframe as original.
  - Secure the assembly using the M8 bolts (Item 10) with M8 washers (Item 2) and M8 nyloc nuts (Item 1) as shown in Picture 14. Tighten the nuts to 20Nm.
  - Take the OEM subharness that was removed earlier, in order to install R&G licence plate illuminator, the OEM wiring needs to be 'cut and shut'. Cut the OEM licence plate illuminator wiring at least 20mm away from its bulb holder (Shown in Picture 15). Peel the end of both wires and crimp female bullet connectors (Item 13) from the kit. Plug in the licence plate illuminator connectors in this scheme:
    - Subharness YELLOW -----→ Licence Plate Illuminator RED
    - Subharness GREEN -----→ Licence Plate Illuminator BLACK
- If licence plate illuminator fails to illuminate, please swap the connectors over.
- If using LP0206BK, reconnect the indicator connectors as original.
  - Reconnect the main square subharness connector to the main OEM harness as original. Tuck in all the wiring in an appropriated location and tidy up using the cable ties (Item 14) provided.
  - It is recommended to have the bike running and test all the lights at this stage.
  - Refit licence plate as original (it may require drilling)
  - **IMPORTANT: IF FITTING A FULL-SIZE LICENCE PLATE AND PLACING IT FAR DOWN ON THE LICENCE PLATE HANGER, THERE IS A SMALL CHANCE OF THE LICENCE PLATE HITTING THE BACK WHEEL UNDER HEAVY LOAD AND OVER LARGE BUMPS IN THE ROAD. IT IS YOUR RESPONSIBILITY TO CHECK FOR THIS POSSIBILITY AND TAKE AVOIDING ACTION. FAILURE TO CHECK THIS COULD RESULT IN SERIOUS INJURY.**
  - Depending on local laws, attach the red reflector in an appropriate location.
  - Refit seat.
  - Test both indicator lights and licence plate illuminator before riding.

ISSUE 1 26/07/2016 (HH)

#### CONSUMER NOTICE

The catalogue description and any exhibition of samples are only broad indications of the Products and R&G may make design changes which do not diminish their performance or visual appeal and supplying them in such state shall conform to the order. The Buyer acknowledges no representation or warranty (other than as to title) has been given or will apply to the Products other than those in R&G's order or confirmation and the Buyer confirms it has chosen the Products as being of merchantable quality and suitable for its particular purposes. Where R&G fits the Products or undertakes other services it shall exercise reasonable skill and care and rectify any fault free of charge unless the workmanship has been disturbed. The Buyer is responsible for ensuring that the warranty on the motorcycle is not affected by the fitting of the Products. On return of any defective Products R&G shall at its option either supply a replacement or refund the purchase money but shall not be liable if the Products have been modified or used or maintained otherwise than in accordance with R&G's or manufacturer's instructions and good engineering practice or if the defect arises from accident or neglect. Other than identified above and subject to R&G not limiting its liability for causing death and personal injury, it shall not be liable for indirect or consequential loss and otherwise its liability shall be limited to the amounts paid by the Buyer for the Products or the fitting or service concerned. These terms do not affect the Buyer's statutory rights.

R&G Racing

Unit 1, Shelley's Lane, East Worldham, Alton, Hampshire, GU34 3AQ

Tel: +44 (0)1420 89007 Fax: +44 (0)1420 87301 [www.rg-racing.com](http://www.rg-racing.com) Email: [info@rg-racing.com](mailto:info@rg-racing.com)



**R&G RACING RETURNS POLICY (NON-FAULTY GOODS)**

Returns must be pre-authorized (if not pre-authorized the return will be rejected). Goods may only be returned direct to us if they were purchased direct from us (customer must prove if necessary). Otherwise to be returned to original vendor. Goods must be in re-sellable condition, in the opinion of R&G Racing. All returns are subject to a 25% restocking and handling fee (25% of the gross value exc. P&P – at the prevailing price at time of purchase). The customer must pay any and all carriage charges. No returns of discontinued products, unless within 14 days of purchase. This policy does not affect your statutory rights and does not refer to faulty goods.



**NOTICE DE MONTAGE POUR LP0206BK SUPPORT DE PLAQUE**  
**HONDA MSX 125 2016-**



**Le kit contient les articles exposés ci-dessous, vérifier que toutes les pièces soient présentes avant de procéder au montage.**

**LA FAÇON DONT LE KIT EST EMBALLE NE CORRESPOND PAS FORCEMENT A LA FAÇON DE MONTER LES PIECES SUR LA MOTO.**

**LES PARTIES PRESENTEES PEUVENT ETRE UNIQUEMENT REPRESENTATIVES (POUR LA CLARTE DES INSTRUCTIONS UNIQUEMENT)**

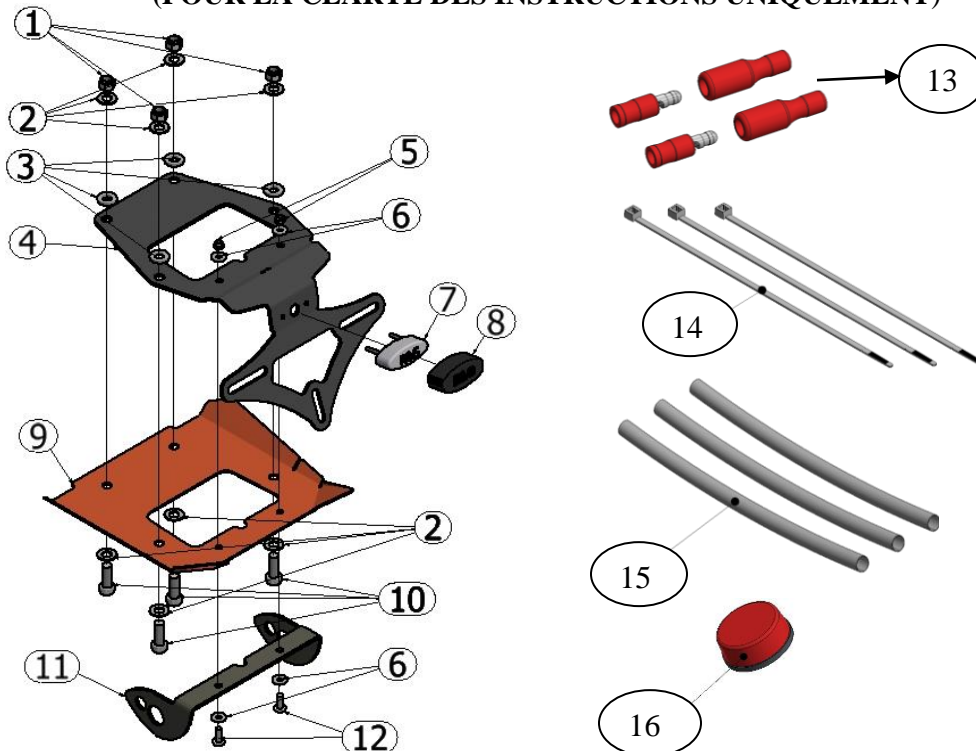

R&G Racing

Unit 1, Shelley's Lane, East Worldham, Alton, Hampshire, GU34 3AQ

Tel: +44 (0)1420 89007 Fax: +44 (0)1420 87301 [www.rg-racing.com](http://www.rg-racing.com) Email: [info@rg-racing.com](mailto:info@rg-racing.com)





## **LEGENDE**

- ARTICLE 1 = M8 Ecrous (x4)
- ARTICLE 2 = M8 Rondelles (x8)
- ARTICLE 3 = Entretoises (S0693) (x4)
- ARTICLE 4 = Support de plaque (TB0206 Partie1) (x1)
- ARTICLE 5 = M5 Ecrous (x2)
- ARTICLE 6 = M5 Rondelles (x4)
- ARTICLE 7 = Feu de plaque (LA0002) (x1)
- ARTICLE 8 = Linceul de feu de plaque (x1)
- ARTICLE 9 = Cache plaque (TB0206 Partie 2) (x1)
- ARTICLE 10 = M6 x 20mm Boulons (x4)
- ARTICLE 11 = Support clignotant standard (TB0206 Partie 3)
- ARTICLE 12 = M5 x 12mm Boulons (x2)
- ARTICLE 13 = Connecteurs (CON004) (x1 set)
- ARTICLE 14 = Colliers de serrage (x3)
- ARTICLE 15 = Manchons thermo rétractables (x3)
- ARTICLE 16 = Réflecteur (x1)

Notez que si les kits sont emballés avec des rondelles en caoutchouc servant à tenir les composants, *ces rondelles doivent être jetées !*

## **OUTILS REQUIS**

- Jeu de clés Allen
- Pincés électriques
- Jeu de clés à pipe 14mm
  - Clé de 13mm
- Tournevis cruciforme
- Un peu de superglue
- Un peu de graisse

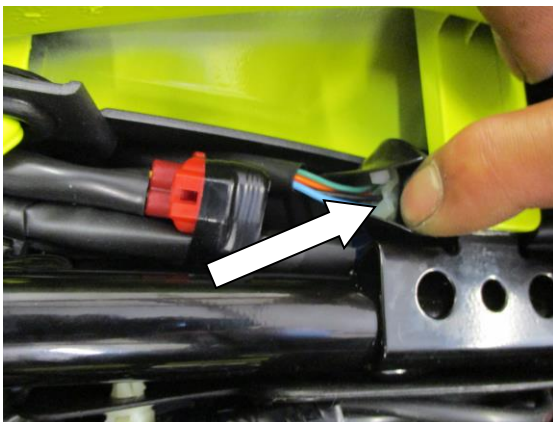

PHOTO 1

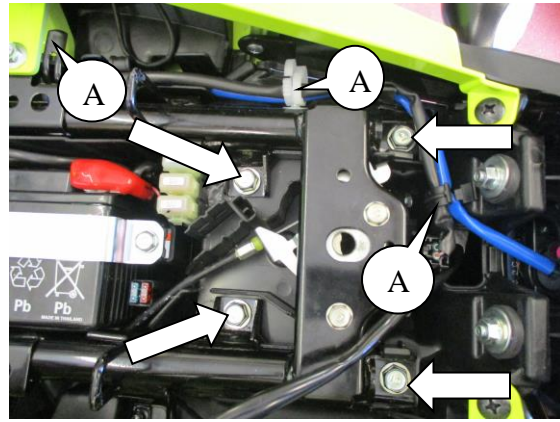

PHOTO 2

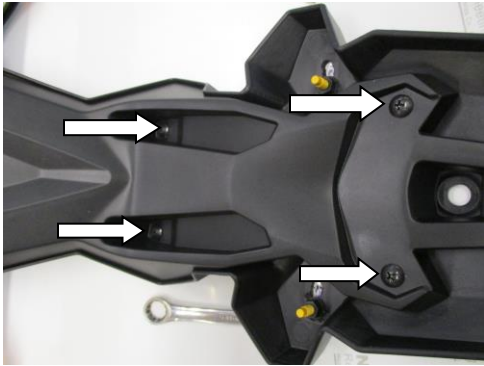

PHOTO 3

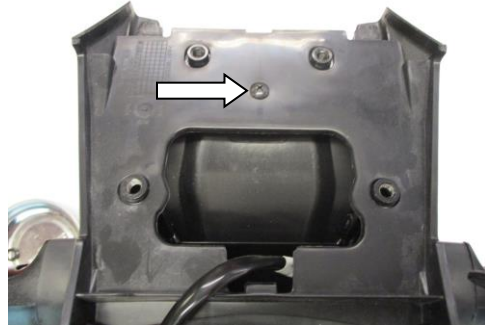

PHOTO 4

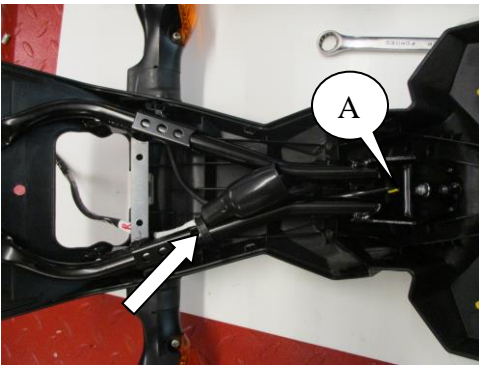

PHOTO 5

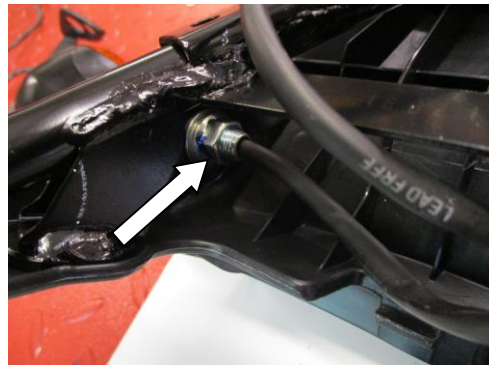

PHOTO 6

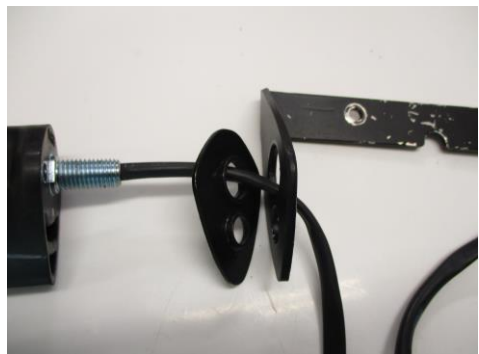

PHOTO 7



PHOTO 8



PHOTO 9

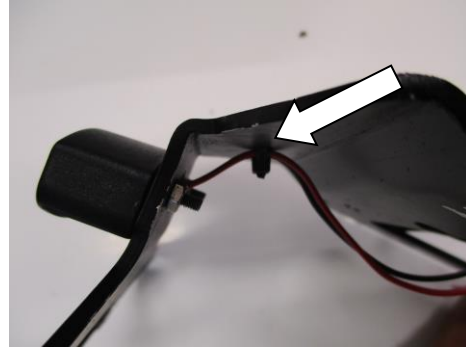

PHOTO 10

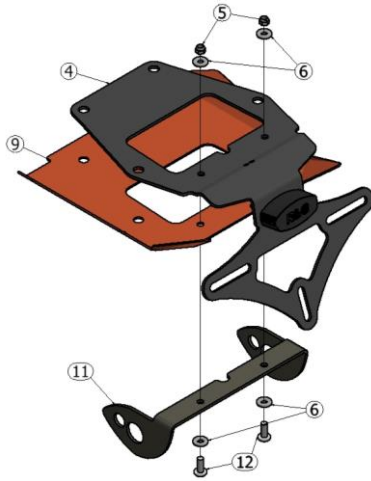

PHOTO 11

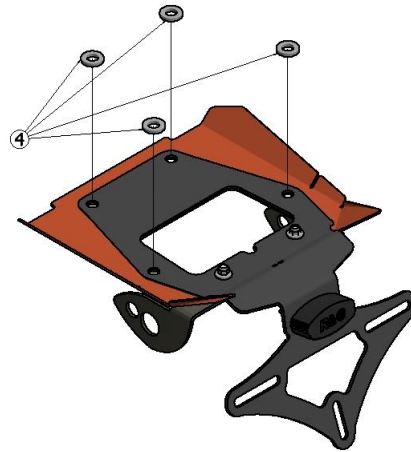

PHOTO 12



PHOTO 13

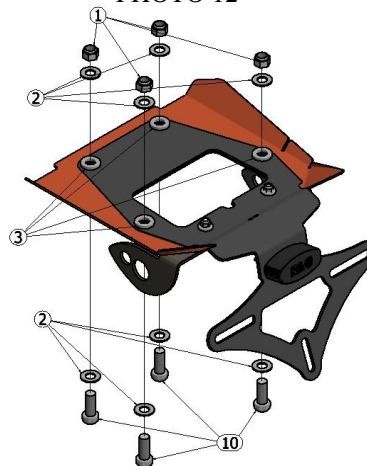

PHOTO 14

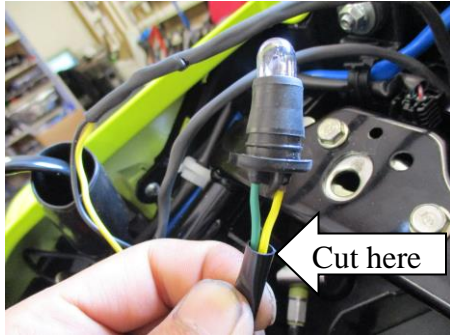

PHOTO 15

### **NOTICE DE MONTAGE**

- Enlever le siège à l'aide de la clé.
- Déconnecter le connecteur de l'unité carrée du feu de plaque placé du côté droit du panneau arrière (voir Photo 1)
- Déclipser tous les garde fils comme indiqué par A, voir Photo 2 et bouger le fil de feu de laque qui vient tout juste d'être connecté.
- Enlever les 4 boulons, voir Photo 2 à l'aide d'une clé à pipe de 14mm. Tenir l'unité de support de plaque tout en desserrant les 4 boulons. Tirer l'assemblage d'unité de plaque et ses fils du sous cadre de la moto et notez l'orientation des fils.
- Sur l'unité de support de plaque d'origine, enlever les 4 vis indiquées sur la Photo 3 à l'aide du tournevis cruciforme.
- Enlever une vis indiquée sur la Photo 4 placée de l'autre côté de l'unité de support de plaque à l'aide d'un tournevis cruciforme. Une fois enlevé, diviser l'empennage en 2 moitiés.
- Déclipser le garde fils, voir Photo 5 et déconnecter les connecteurs de clignotants (notez l'orientation des connecteurs). Tirer doucement le support feu de plaque à ampoule d'origine de son emplacement puis enlever l'ampoule de son support (indiqué A sur la Photo 5).
- Enlever le sous harnais de l'unité de support de plaque.
- A l'aide d'une clé de 13mm, enlever les 2 clignotants en enlevant l'écrou, voir Photo 6. Notez la position de la plaque de protection du clignotant pendant le démontage.
- Si vous utilisez le kit LP0206BK, prendre le support clignotant (Article 11) et monter les 2 clignotant d'origine avec la plaque de protection, voir Photo 7. Fixer les clignotants à l'aide des écrous d'origine. Assemblage terminé visible sur la Photo 8.
- Dans le kit, prendre le support de plaque (Article 4) et le feu de plaque (Article 7). Monter le feu de plaque (Article 7) dans les 3 trous alignés sur le support de plaque (Article 4), voir Photo 9 et fixer à l'aide des rondelles et écrous M3 fournis dans le kit. Prendre le lincol de feu de plaque (Article 8) et appliquer un peu de superglue à l'intérieur puis placez-le autour du feu de plaque (Article 7). Insérer les 2 fils rouge et noir dans le manchon thermo rétractable fourni dans le kit puis rétrécir le manchon à l'aide d'une source de chaleur adéquate.
- Dans le kit, prendre un collier de serrage fourni puis encerclez les autour des 2 petits trous placés au centre du support de plaque (Article 4). Fixer le fil de feu de plaque (Article 7) avec un collier de serrage tout juste placé, voir Photo 10.
- Dans le kit, prendre la plaque de cache (Article 9) et placez la sous le support de plaque (Article 4). Veiller à ce que les zones pliées de la plaque de cache soient orientées vers le haut. Aligner tous les trous 5mm et 8mm ensemble.

R&G Racing

Unit 1, Shelley's Lane, East Worldham, Alton, Hampshire, GU34 3AQ

Tel: +44 (0)1420 89007 Fax: +44 (0)1420 87301 [www.rg-racing.com](http://www.rg-racing.com) Email: [info@rg-racing.com](mailto:info@rg-racing.com)



- Prendre l'assemblage de support de plaque et positionnez le sous la plaque cache avec les 2 trous de 5mm alignés, voir Photo 11. Fixer l'assemblage à l'aide des boulons M5 (Article 12) et rondelles M5 (Article 6), et écrous M5 (Article 5) du kit. Serrer les écrous à 12Nm.
  - Appliquer un petit filet de graisse sur la surface de chaque entretoise (Article 3) fournie dans le kit. Placer chaque entretoise sur un trou 8mm du support de plaque (Article 4). Indiquée sur la Photo 12. La graisse est utilisée pour garde les entretoises en place lors du montage.
  - Monter l'assemblage contre le sous cadre de la moto avec tous les fils positionnés dans la fente fournie (voir Photo 13). Placer les fils autour du sous cadre comme à l'origine.
  - Fixer l'assemblage en utilisant les boulons M8 (Article 10) avec rondelles M8 (Article 2) et écrous M8 (Article 1) voir Photo 14. Serrer les écrous à 20Nm.
  - Prendre le sous harnais d'origine qui a été enlevé plus tôt, pour installer le feu de plaque R&G, le fil d'origine doit être coupé puis fermé. Couper le fil de feu de plaque d'origine à 20mm du support ampoule (voir Photo 15). Peler l'extrémité des 2 fils et sertir les connecteurs femelles (Article 13) du kit. Brancher les connecteurs des feux de plaque selon ce schéma :
    - Sous harnais JAUNE -----→ Feu de plaque ROUGE
    - Sous harnais VERT -----→ Feu de plaque NOIR
- Si l'éclairage du feu de plaque échoue, tournez les connecteurs.
- Si vous utilisez la LP0206BK, reconnecter les connecteurs de clignotants comme à l'origine..
  - Reconnecter le connecteurs du sous harnais carré principal sur le harnais d'origine principal comme à l'origine. Ranger tous les fils puis serrer à l'aide des colliers de serrage (Article 14) fournis.
  - Tester la moto et tous les feux à ce stade.
  - Remettre le siège et la plaque (peut nécessiter un perçage).
  - **IMPORTANT: Si vous installez une grosse plaque, il y a un risque que la plaque entre en contact avec la roue arrière en cas de choc sur la route (bosse, grosse charge etc...). Il est de votre responsabilité de vérifier que cela ne puisse pas se produire. Ne pas effectuer ces vérifications peut entraîner des dommages ainsi que des blessures graves pour le pilote.**
  - Selon la loi locale, attachez le réflecteur (article 16) fourni à son emplacement approprié.
  - Remonter le siège.
  - **Vérifiez que les clignotants et les feux de plaque fonctionnent bien avant de prendre la route.**

ISSUE 1 26/07/2016 (HH)

#### CONSUMER NOTICE

The catalogue description and any exhibition of samples are only broad indications of the Products and R&G may make design changes which do not diminish their performance or visual appeal and supplying them in such state shall conform to the order. The Buyer acknowledges no representation or warranty (other than as to title) has been given or will apply to the Products other than those in R&G's order or confirmation and the Buyer confirms it has chosen the Products as being of merchantable quality and suitable for its particular purposes. Where R&G fits the Products or undertakes other services it shall exercise reasonable skill and care and rectify any fault free of charge unless the workmanship has been disturbed. The Buyer is responsible for ensuring that the warranty on the motorcycle is not affected by the fitting of the Products. On return of any defective Products R&G shall at its option either supply a replacement or refund the purchase money but shall not be liable if the Products have been modified or used or maintained otherwise than in accordance with R&G's or manufacturer's instructions and good engineering practice or if the defect arises from accident or neglect. Other than identified above and subject to R&G not limiting its liability for causing death and personal injury, it shall not be liable for indirect or consequential loss and otherwise its liability shall be limited to the amounts paid by the Buyer for the Products or the fitting or service concerned. These terms do not affect the Buyer's statutory rights.

R&G Racing

Unit 1, Shelley's Lane, East Worldham, Alton, Hampshire, GU34 3AQ

Tel: +44 (0)1420 89007 Fax: +44 (0)1420 87301 [www.rg-racing.com](http://www.rg-racing.com) Email: [info@rg-racing.com](mailto:info@rg-racing.com)



**R&G RACING RETURNS POLICY (NON-FAULTY GOODS)**

Returns must be pre-authorized (if not pre-authorized the return will be rejected). Goods may only be returned direct to us if they were purchased direct from us (customer must prove if necessary). Otherwise to be returned to original vendor. Goods must be in re-sellable condition, in the opinion of R&G Racing. All returns are subject to a 25% restocking and handling fee (25% of the gross value exc. P&P – at the prevailing price at time of purchase). The customer must pay any and all carriage charges. No returns of discontinued products, unless within 14 days of purchase. This policy does not affect your statutory rights and does not refer to faulty goods.



R&G Racing  
Unit 1, Shelley's Lane, East Worldham, Alton, Hampshire, GU34 3AQ  
Tel: +44 (0)1420 89007 Fax: +44 (0)1420 87301 [www.rg-racing.com](http://www.rg-racing.com) Email: [info@rg-racing.com](mailto:info@rg-racing.com)